

# Soleo 6038

**Geolam**<sup>®</sup>  
Architectural Eco-Technology

## Hybrid Aluminum/WPC Architectural Elements

Datasheet

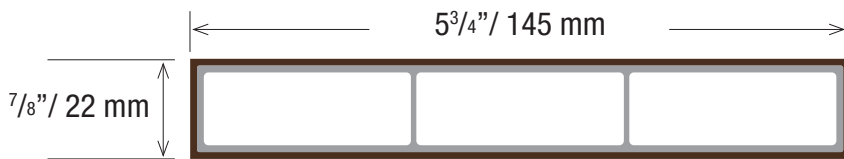

*Technical information may change without warning.  
Please ensure you that you reference our latest as shown on our website at [www.usa.geolam.com](http://www.usa.geolam.com)*

**Thickness:** 7/8 in | 22 mm

**Width:** 5 3/4 in | 145 mm

**Section tolerances in mm:** + 0.5 / - 2.0

**Fire rating:**

Non-combustible as per ASTM E-136 (appendix)

**Surfaces finish:** Sanded

**Profiles fastening and installation:**

Check our website [www.usa.geolam.com](http://www.usa.geolam.com)

**Standard length:** 9 ft 10 in | 3.0 m

**Or order custom lengths from:**

7 ft to 19 ft 8 in | 2.15 m to 6 m

**Weight:** 1.34 lb/ft | 2.00 kg/m

**Secondary moment Ix (cm<sup>4</sup>):** 3.47

**Secondary moment Iy (cm<sup>4</sup>):** 97.77

**Section modulus Z+x (cm<sup>3</sup>):** 3.65

**Section modulus Z-x (cm<sup>3</sup>):** 3.65

**Section modulus Z+y (cm<sup>3</sup>):** 13.77

**Section modulus Z-y (cm<sup>3</sup>):** 13.77

**Core in anodized aluminum alloy:**

A6063S-T5 Serie 6000

**Coefficient of Thermal Expansion (20-100°C):**

23.4 μm/m/°C

**Modulus of Elasticity:** 68.9 GPa

**Max Tensile Strength:** 186 Mpa

**Carbon Footprint:**

WPC : 1.54 kg CO<sub>2</sub> /Kg

Profile : 9.005 kg CO<sub>2</sub> /Kg

*Sanding finish and/or shading may vary between runs*

**Standard Colors** - Minimum 1,600 lineal ft. for all colors.



Teak



Moleskin



Rosewood



Ebony

**Non-Standard Colors** - 90 day lead time - Minimum order 5,000 lineal ft.



Carbon



Bilinga

**Custom Colors Available** - Minimum order 6,000 lineal ft.

[usa.geolam.com](http://usa.geolam.com)  
Toll free: 1-877-627-3530  
[info@geolaminc.com](mailto:info@geolaminc.com)

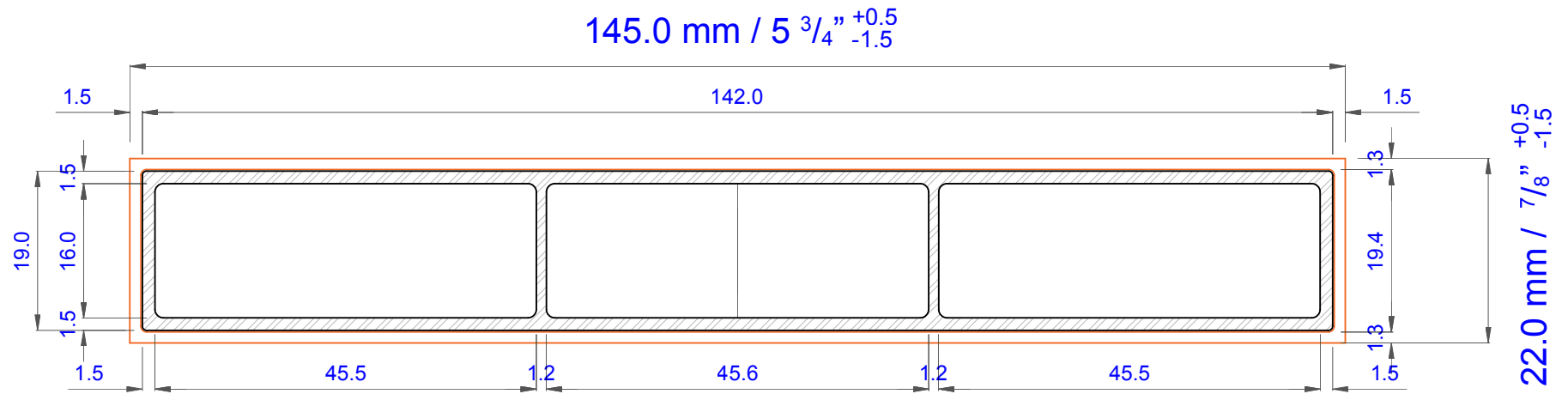

<b>Technical specifications, dimensions in mm</b>		Cross section coefficient Z+x (cm <sup>3</sup> )	3.65	<b>Wood hybrid system WHS</b>	Type 1.0	 <a href="http://www.geolaminc.com">www.geolaminc.com</a>
Weight (kg/ml)	2.00	Cross section coefficient Z-x (cm <sup>3</sup> )	3.65	<h1>Soleo 6038</h1>		
Cross section, secondary moment Ix (cm <sup>4</sup> )	3.47	Cross section coefficient Z+y (cm <sup>3</sup> )	13.77			
Cross section, secondary moment Iy (cm <sup>4</sup> )	97.77	Cross section coefficient Z-y (cm <sup>3</sup> )	13.77			