

Architectural Elements Package

PROJECT:

COMPANY:

GENERAL CONTRACTOR:

ARCHITECT:

LOCATION:

GEOLAM ARCHITECTURAL ELEMENTS

TABLE OF CONTENTS

1. Installation Guide
2. Product Specs
3. Span Charts
4. Geolam Warranty

INSTALLATION AND MAINTENANCE GUIDE

Architectural Elements

© Five Architects

Shibusu, Sarasota, FL
Soleo 6008 - Moleskin

Geolam[®]
Architectural Eco-Technology

info@geolaminc.com
usa.geolam.com



Geolam Architectural Elements

Façades, sunshades, screens and more architectural elements

Installation options are suggestions only

Geolam®: a stunning alternative to hardwood architectural trim

Geolam's line of architectural trim is the outcome of years of research. The result is an exclusive process of co-extrusion whereby an aluminum core section is fabricated with an outer covering, or skin, of composite wood.

Geolam's hybrid aluminum/WPC products provide the look of stained wood and provide long term performance with low maintenance.

These profiles exhibit the strength, stability, and versatility of aluminum with the warmth and aesthetic of natural wood. Light and easy to install, this hybrid aluminum/WPC material is used for facades, sunshades, screens and other architectural accents.

Cutting the profiles

- Use motorized tools and specialized aluminum-cutting chip saws when cutting Geolam hybrid profiles.
- Do not use grinders or chainsaws for cutting.
- Not using a suitable aluminum-cutting chip saw could result in deformation, cracks and/or peeling of the product.

Aluminum Saw Blade

Base Metal: Tool Steel

Chips: Carbide

Teeth: Minimum 2 teeth per centimeter



Cutting Speed

- Maximum 2 meters per minute

Cutting Direction

- To cut, pull the product in the same direction as the saw rotation, as shown in the illustration below.
- Cutting in the opposite direction may cause the product to move, which may produce an untidy cut in addition to being dangerous for the operator.

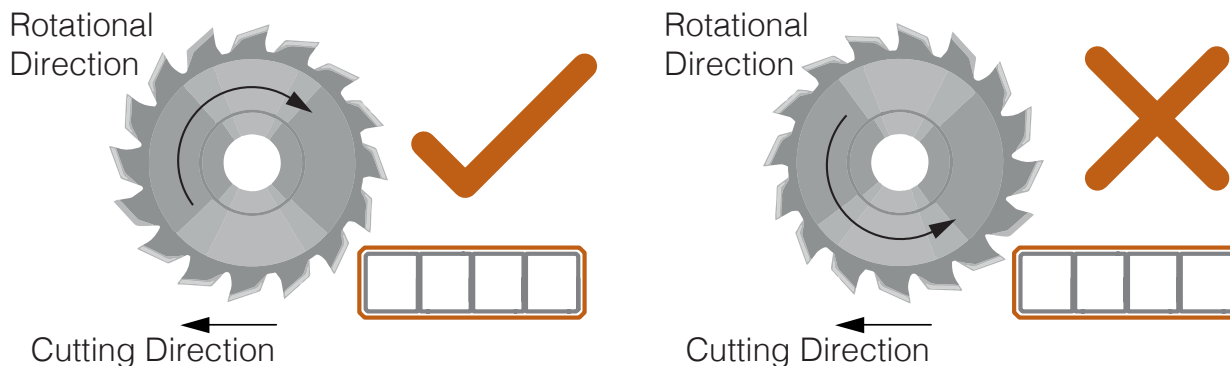

IMPORTANT MESSAGE FOR CUTTING PLANEBO BOARDS ONLY:

Planeo boards consist of other Geolam hybrid profiles, usually Soleo, that are bolted internally to produce a larger board. The bolts are usually placed 2 – 4 ft apart depending on the profile and are inset approx 2" at the end of each board. The boards can be field cut with a small tooth saw to shorten them but only the 2" on the ends that stick out past the end bolts. Please do not cut these boards anywhere else. This may compromise the structural integrity of the board.

Drilling holes in profiles

- Use drills for use with metal or timber and make the holes with a tabletop drilling machine or a motorized screwdriver.
- Drilling holes through both sides of the material may result in the formation of burrs or chips when the drill exits the rear side.
- Therefore, test the machine on scrap material before starting work.
- If burrs do appear, drill through from both sides independently.
- Depending on how the burrs are formed, the surface layer could be chipped to reveal the aluminum core beneath.

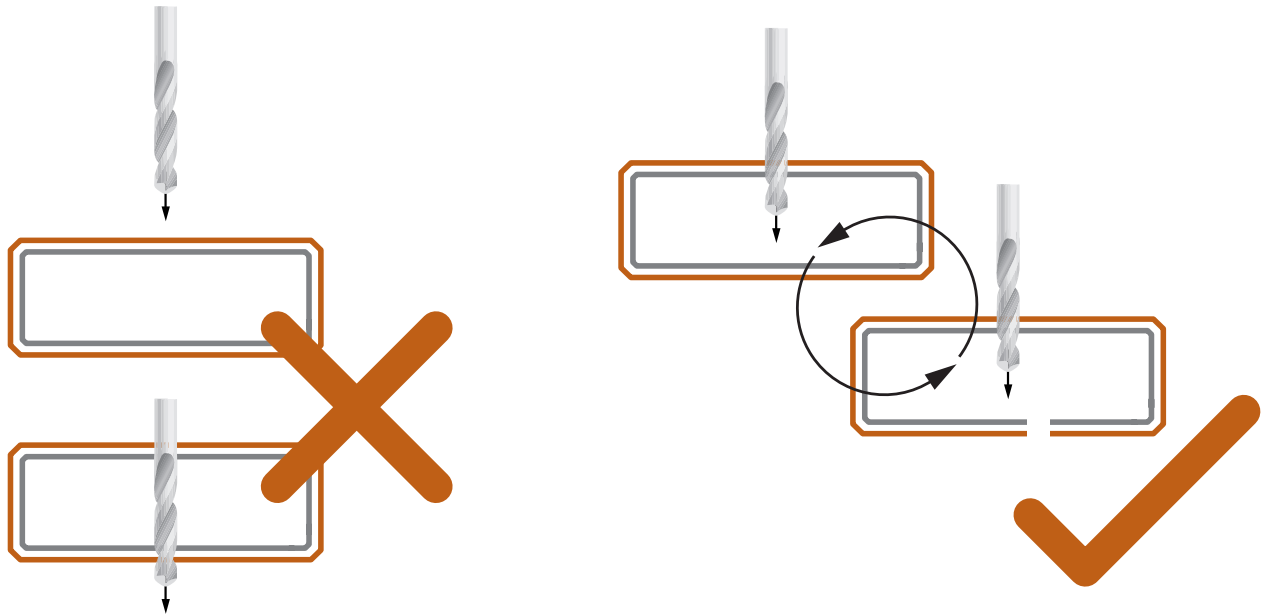

INSTALLATION OPTIONS

Fastening profiles using InPull nut

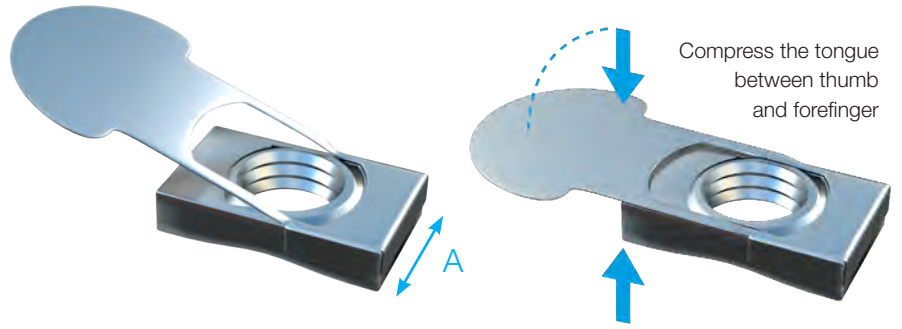

Compress the tongue between thumb and forefinger

Bolt Size	Prehole Diameter (mm)	Nut Width A (mm)	Max Torque (Nm)	Max Tension Load (kN)
M6	10.2	9.5	10.0	7.8
M8	12.7	12.0	24.5	14.7
M10	15.7	14.3	39.2	19.6
M12	18.0	16.9	58.8	29.4

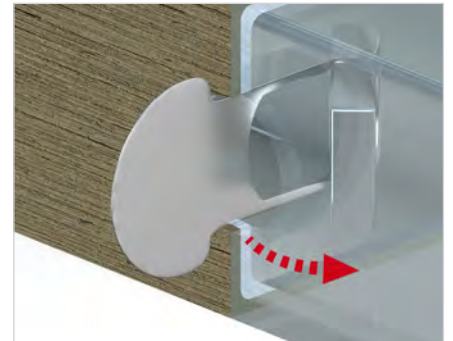
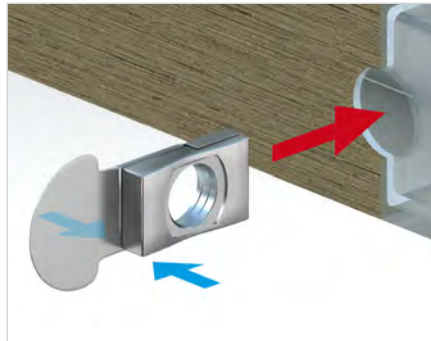
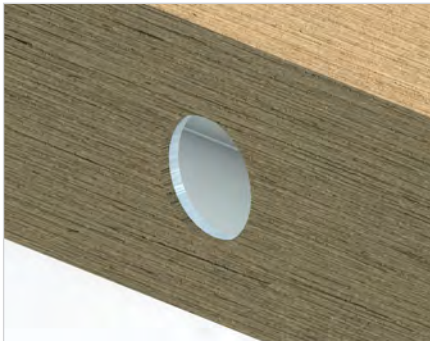

Pre-drill as shown (see above table for diameter). Select the correct InPull nut (M6 to M12) according to your fastening requirements.

Insert the InPull nut as shown. Squeeze the tongue as you insert the nut and release once the nut is in place. Once released the nut will rest at an angle to the inside of the board.

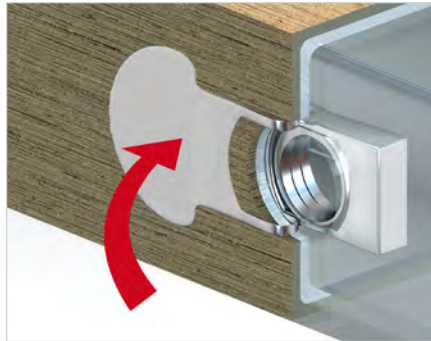
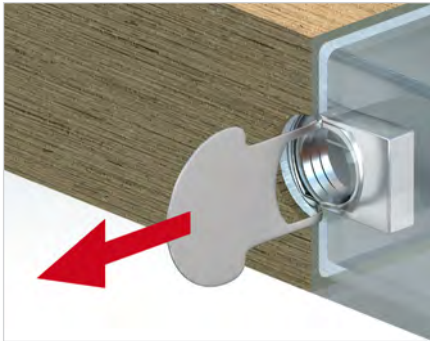

Pull out the tongue so as to secure the nut along the inside of the board.

Lay the tongue along the exterior of the board, if necessary fasten with tape to hold it.



Installation of the supporting structure

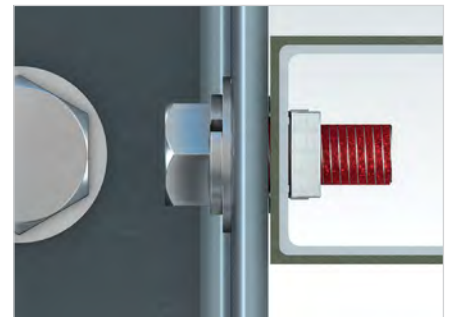

Example of assembly brackets attached with bolts and anaerobic glue e.g. "thread locker". The pre-drilled holes are wider than the bolt shaft (2 to 4 mm) to allow for expansion of the board. Washers are required as shown.

INSTALLATION OPTIONS

Fastening profiles using blind nut

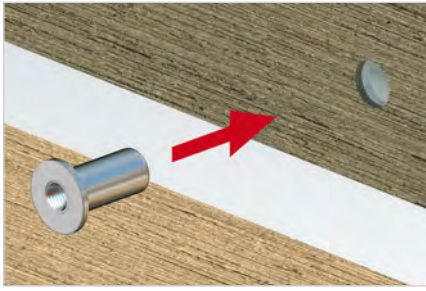

Pre-drill as shown.



Select the correct blind nut according to your fastening requirements.

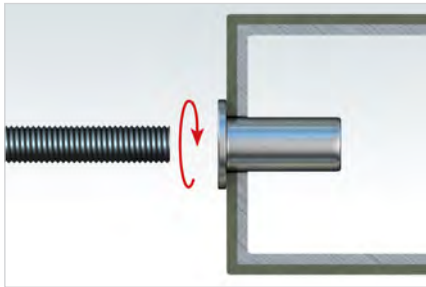

Setting the blind nuts
(manual or pneumatic tool).

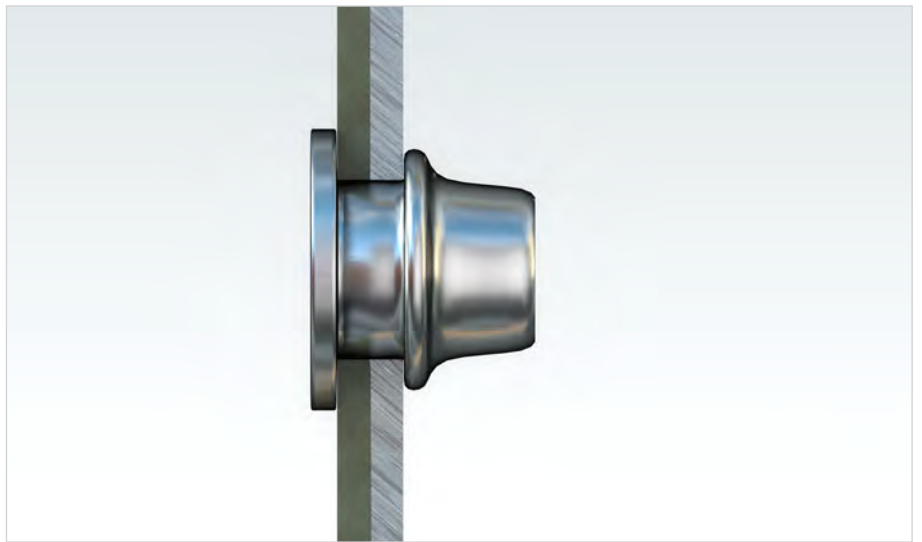
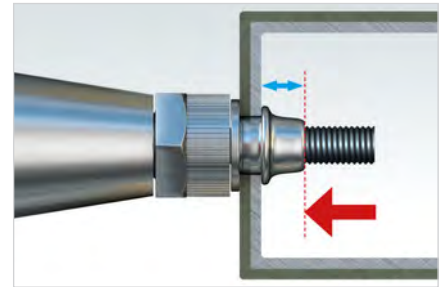
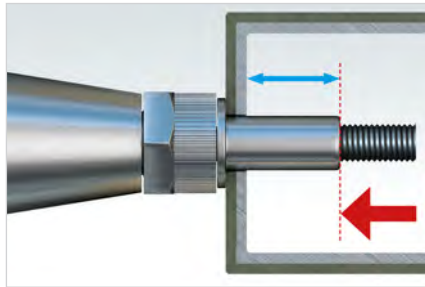

Installation of the supporting structure. The pre-drilled holes are wider (2 to 4 mm) than the bolt shaft to allow for expansion of the board. Washers are required as shown.

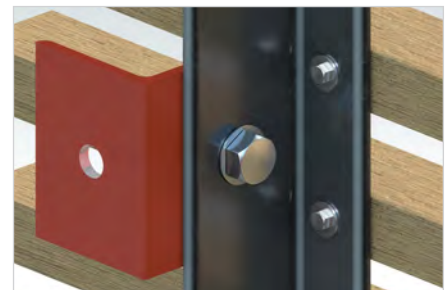
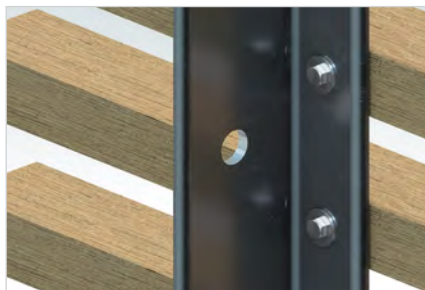

INSTALLATION OPTIONS

Fastening profiles using self-tapping screw



Some profiles (as example shown above) have some aluminum walls that are thicker. You may take advantage of these for a more secure fastening.



Installation of the supporting structure. The pre-drilled holes are wider (2 to 4 mm) than the bolt shaft to allow for expansion of the board. Washers are required as shown.

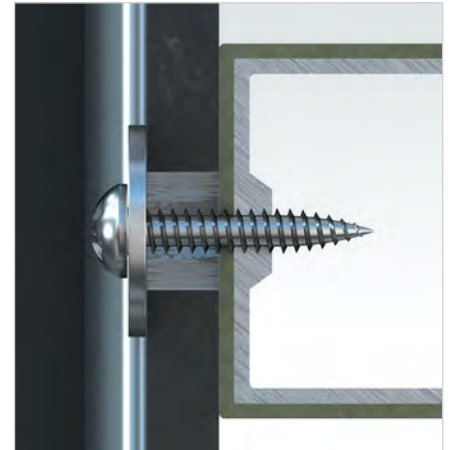
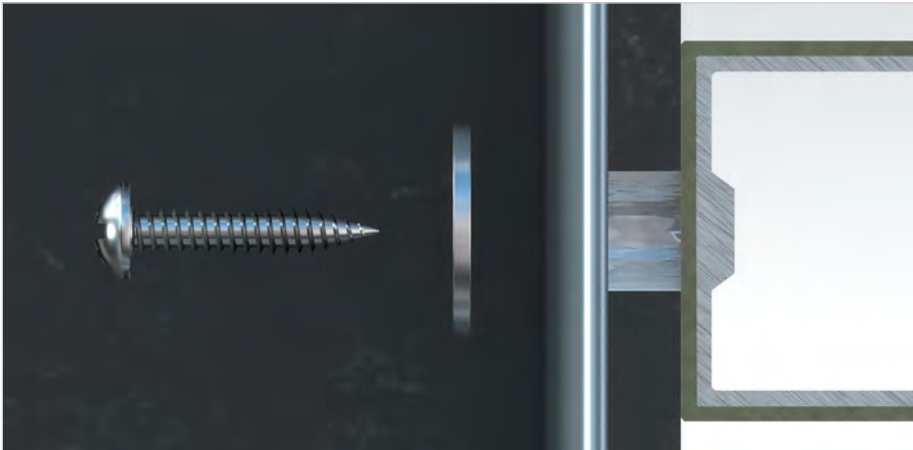

Example of assembled brackets.

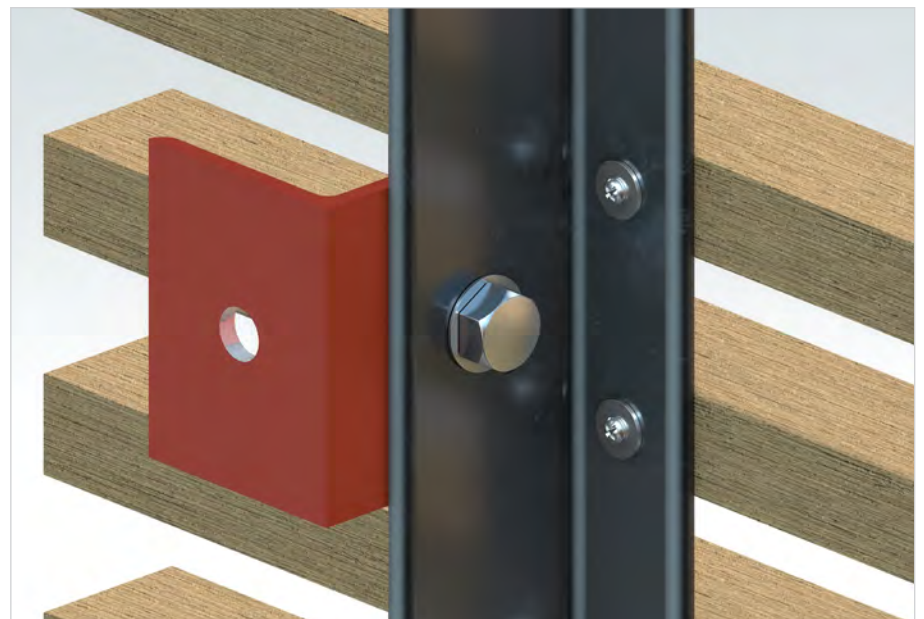
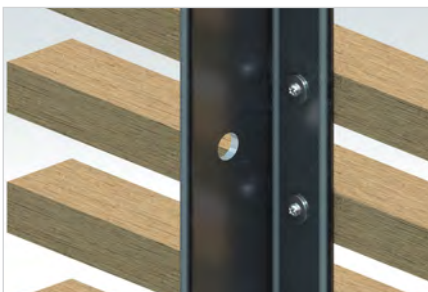

INSTALLATION OPTIONS

Fastening profiles using flange bolt

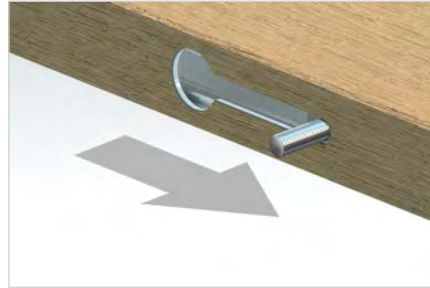
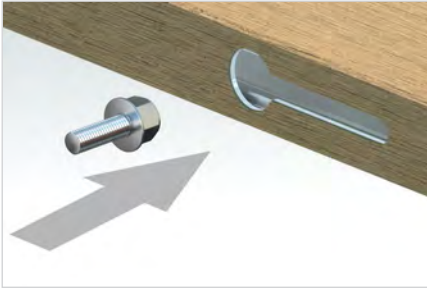

Setting up the first flange bolt.

Setting up the second flange bolt.

For specific profile only, use flange bolts allows a strong fixation (example: Soleo 6032 installed sideways).

According to the picture, drill a specific oblong hole using a numerically controlled milling machine.

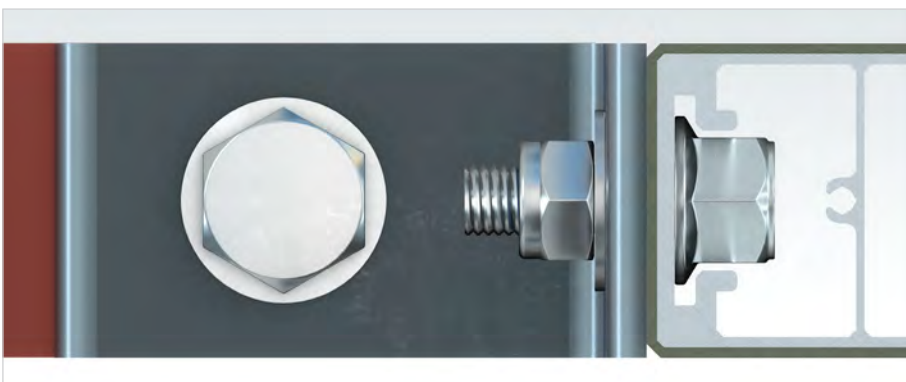
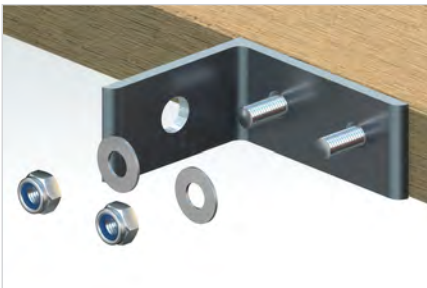
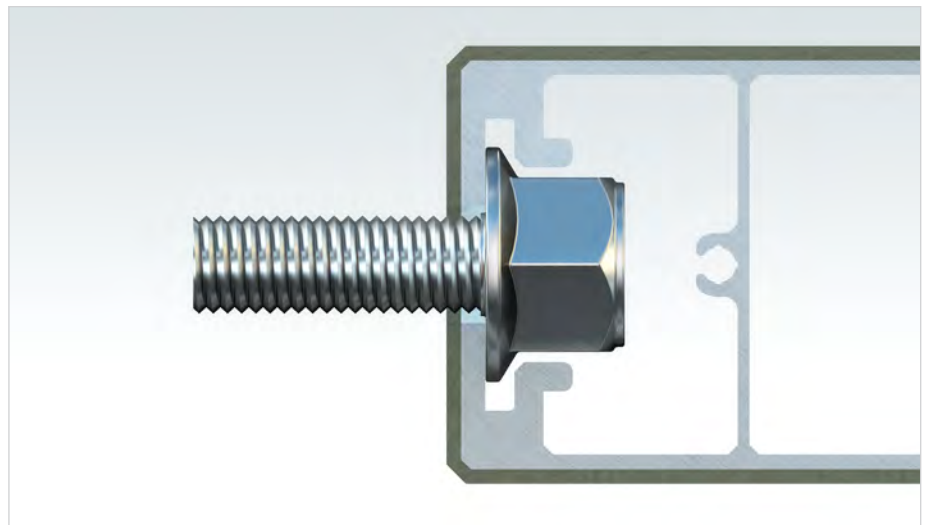

Example of fixation on assembly brackets using braked nuts.

INSTALLATION OPTIONS

Bolt nuts, in-pull nuts and turn nuts

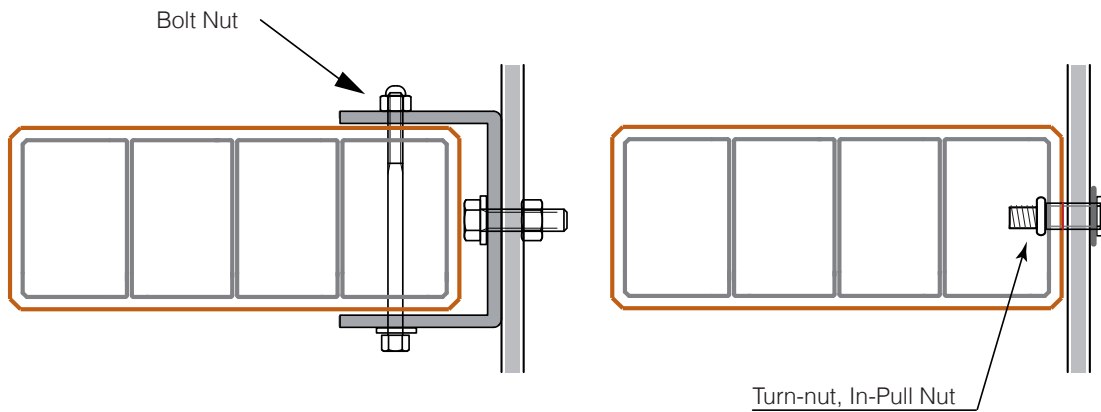

- Fix bolt-nuts, in-pull nuts, and turn-nuts firmly in place (recommended at 3.5Nm).
- Over-tightening may result in deformities, cracks and/or peeling appearing on the surface layer.
- Consult a local building code for joint span and bolt size requirement.
- Fixing the product in place with tapping screws or drill screws is not recommended.
- Nails must also not be used for fixing.
- Check the strength requirement prior to fixing to joint.

[Click here to watch Soleo 6010 Installation video](#)

[Click here to watch suggested louver assembly/installation video](#)

[Click here to download a pdf on Sample Ways to Fasten Architectural Elements](#)

INSTALLATION OPTIONS

Straight Connector

These cleverly designed splices are inserted into the interior of the hybrid profiles. They allow for the assembly of profiles by ensuring proper alignment at butt ends for a straight run.

Only 1 connector needed but you may use 2 connectors per profile for a stronger assembly.

1. Embossing to maintain the connector in place
2. Center line of connector
3. Smooth surface for sliding in and out the module

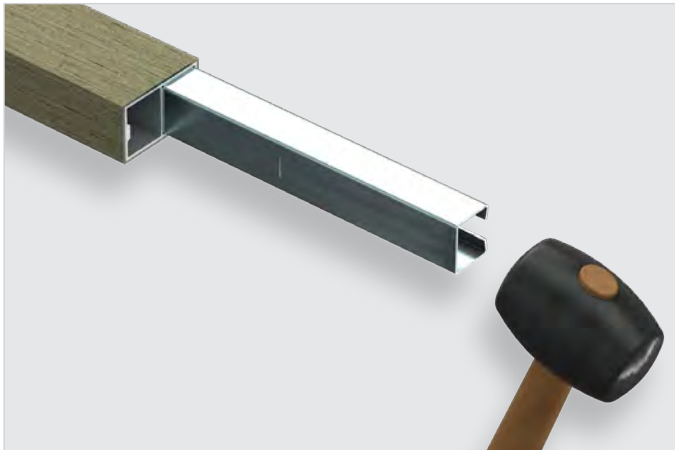
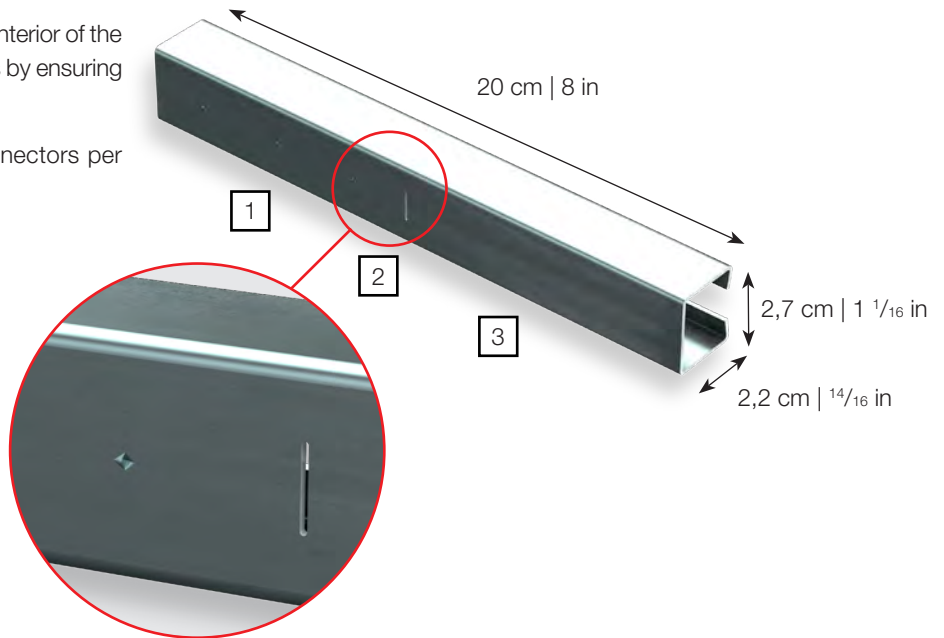

Install the connector using a mallet.

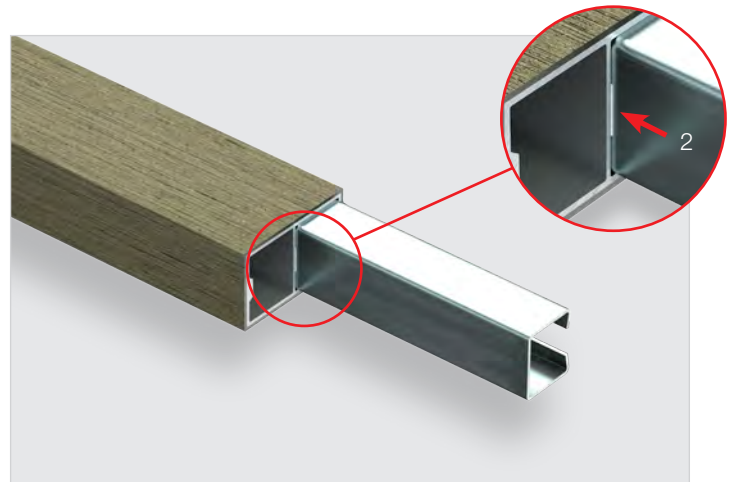

Insert the connector as far as the center line.

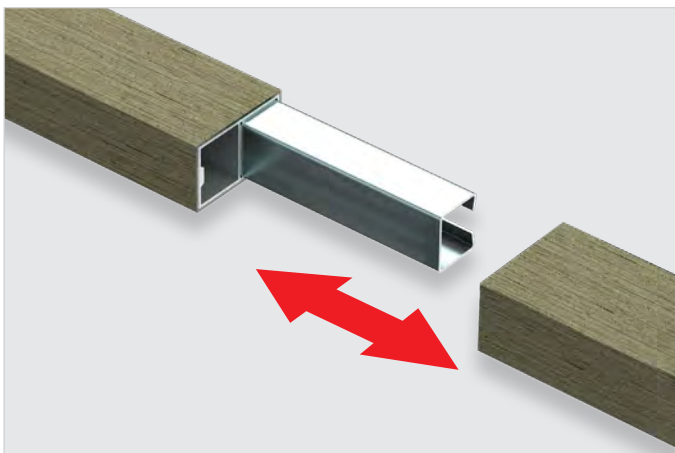

The right-hand profile slides easily in and out.



Joint is almost invisible.

INSTALLATION OPTIONS

Corner Connector (Lying down)

These cleverly designed splices are inserted into the interior of the hybrid profiles. They allow for the assembly of profiles by ensuring proper alignment to create a perfectly finished 90° angle.

Only 1 connector is used in this orientation.

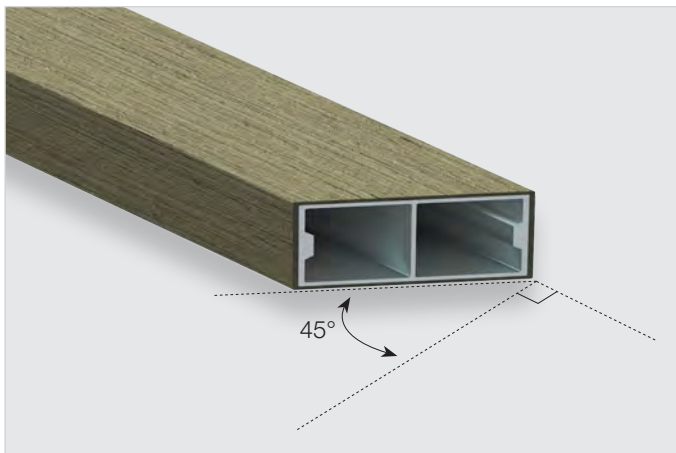
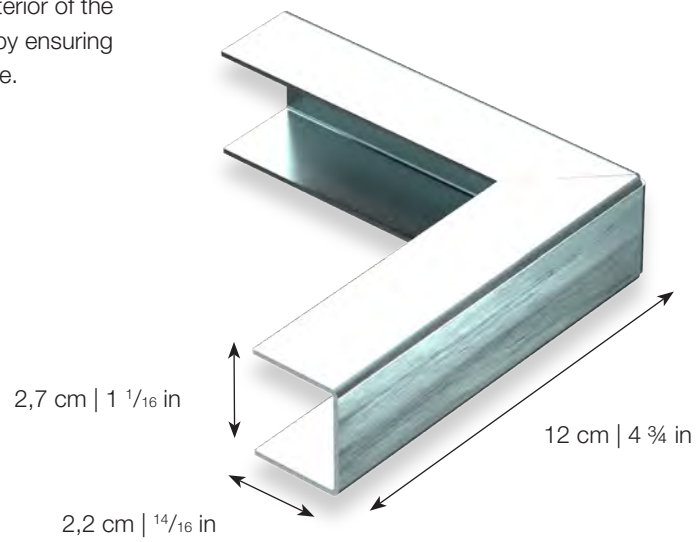
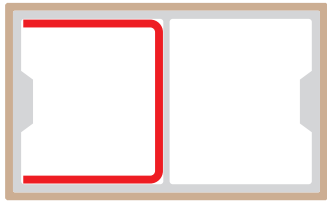

45° cut.

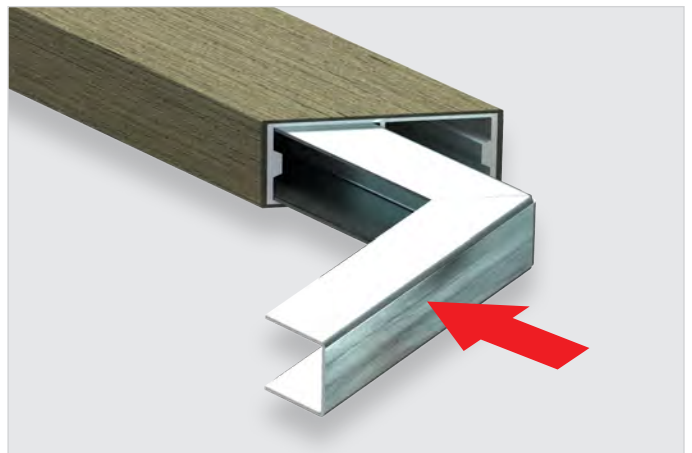

Insert the connector.

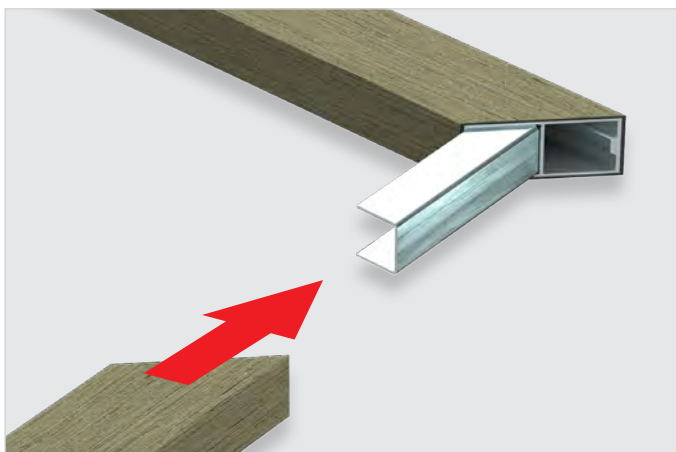

Insert profile.



Joint is almost invisible.

INSTALLATION OPTIONS

Corner Connector (Standing up)

These cleverly designed splices are inserted into the interior of the hybrid profiles. They allow for the assembly of profiles by ensuring proper alignment to create a perfectly finished 90° angle.

Only 1 connector is needed but use 2 connectors per profile for a stronger assembly.

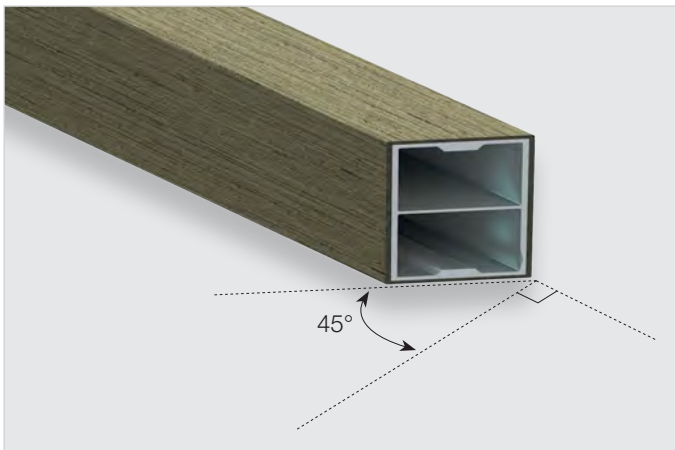
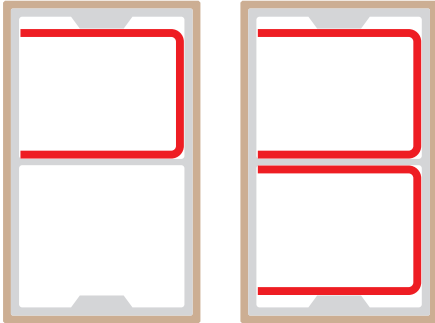
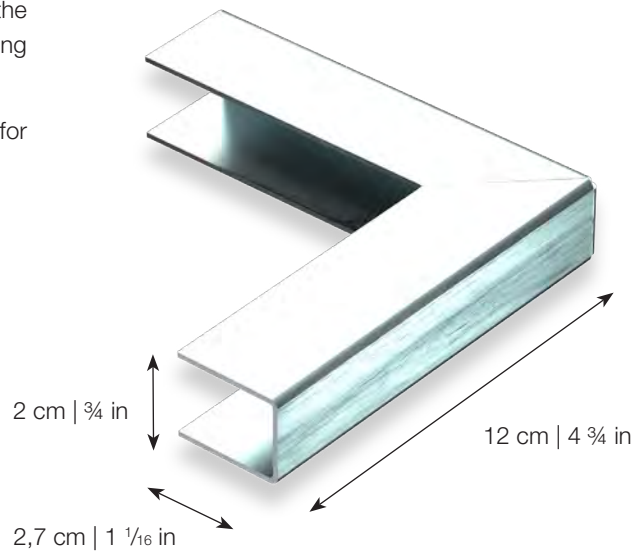

45° cut.

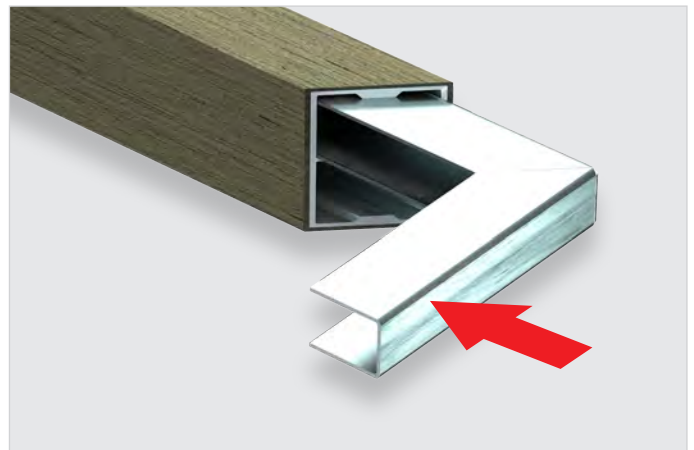

Insert the connector(s).

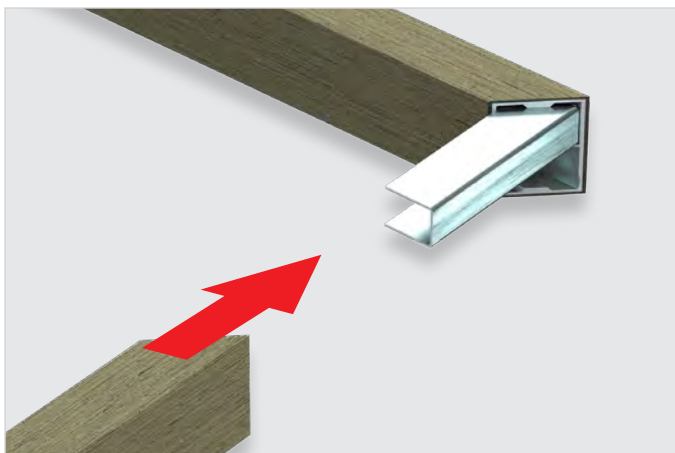

Insert profile.



Joint is almost invisible.

INSTALLATION OPTIONS

Using plugs



Drilling the profile

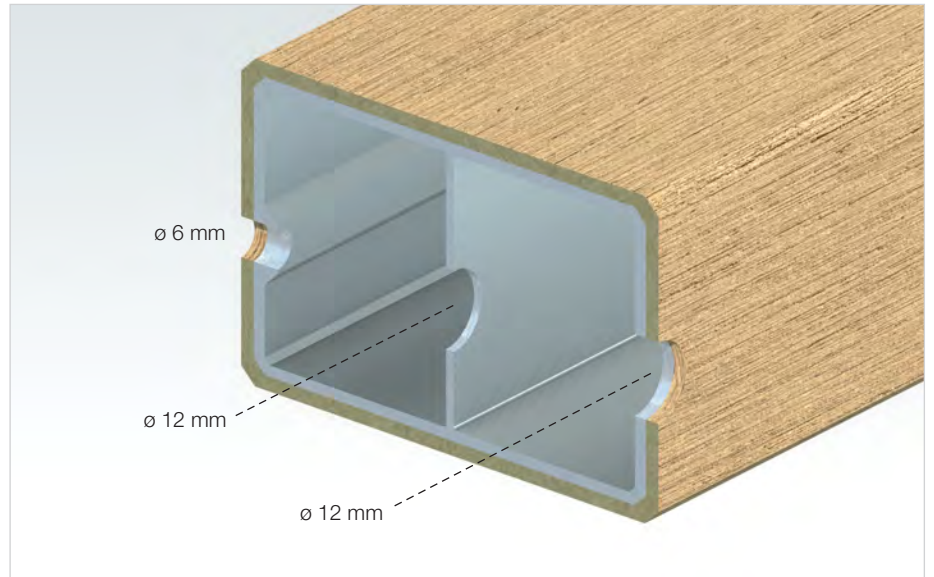

Drill a 6 mm hole, then re-drill a 12 mm hole as far as the inside of the fastening surface

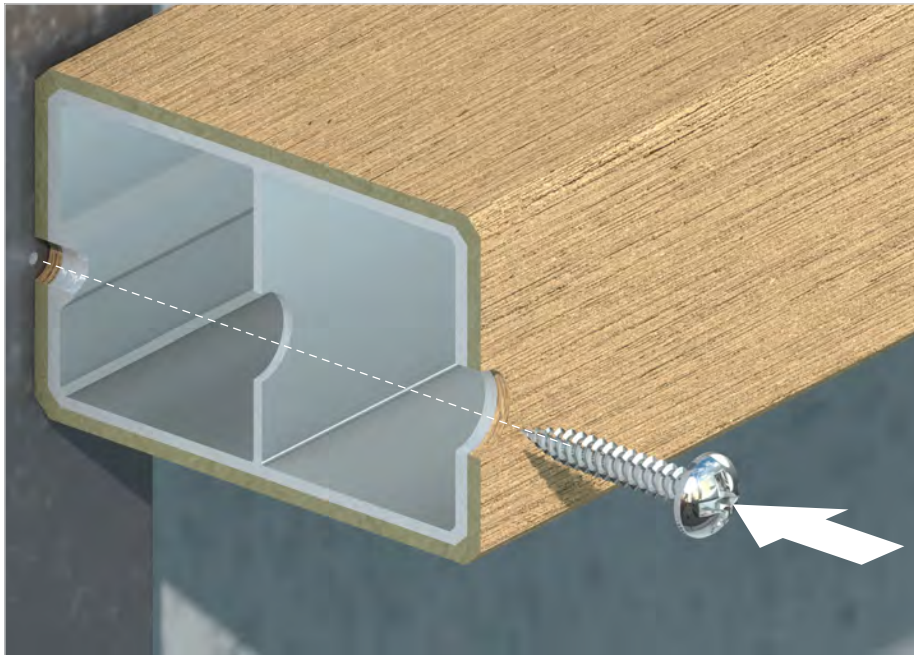

Setting up the screw in the profile

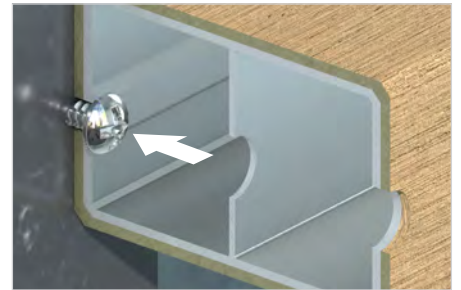

Fasten the screw - stainless steel



Insert the plug



Hammer in plug with rubber mallet



Sand lengthwise with #24 grain sandpaper

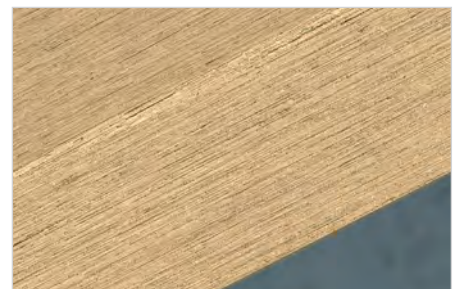

Finished profile

INSTALLATION OPTIONS

WPC and ASA end caps installation

The end caps have to be glued to the profile. The end caps have four openings to allow for weeping of condensation – these must not be blocked or closed up. For a perfect aesthetic, wood composite end caps (WPC) can be adapted in size to the profile or showcased by an appropriate additional sanding by hand.

End caps must be glued to the WHS profile.

Use glue like Sikaflex®: Crystal Clear or 3M®: DP- 8010 :

- Designed to glue plastic (PP and PE) with Aluminum
- Moisture resistant
- Made for extreme temperature fluctuations (-30°C to + 75°C)
- Transparent



WPC end cap



ASA end cap

Fix the end cap by following the 4 steps below

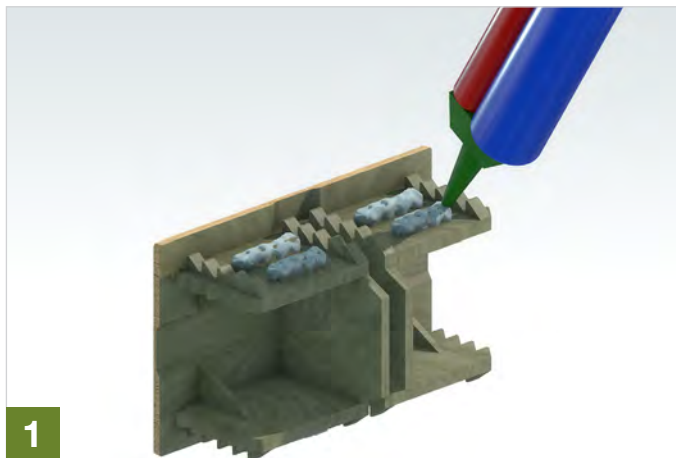

1

Ensure that the surfaces of the clip and the aluminum are clean. Apply one drop of quick-drying glue to each side of the end cap.

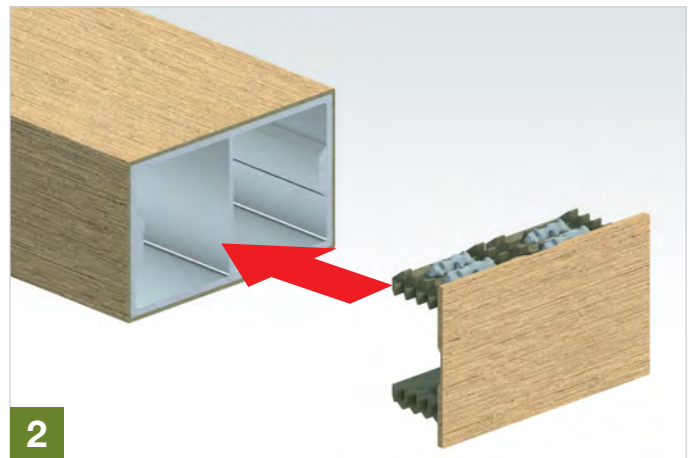

2

Insert the cap into the end of the WHS profile and make sure that NO adhesive has come out on the sides. If so, clean quickly.

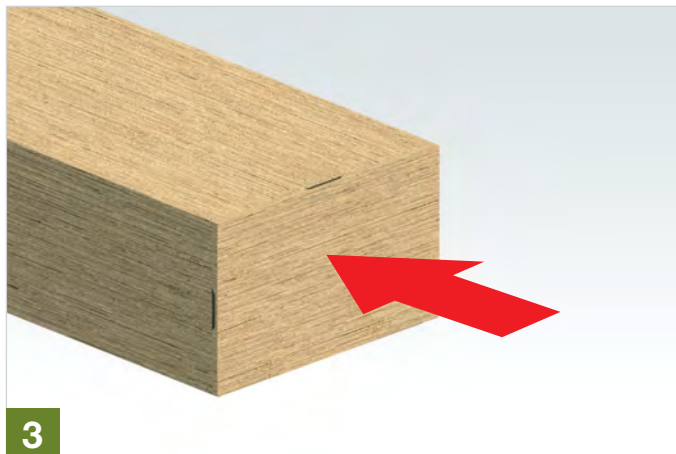

3

Press on the end cap with fingers and hold for about 5 seconds. Make sure that there is no gap between the WHS profile and the end cap.

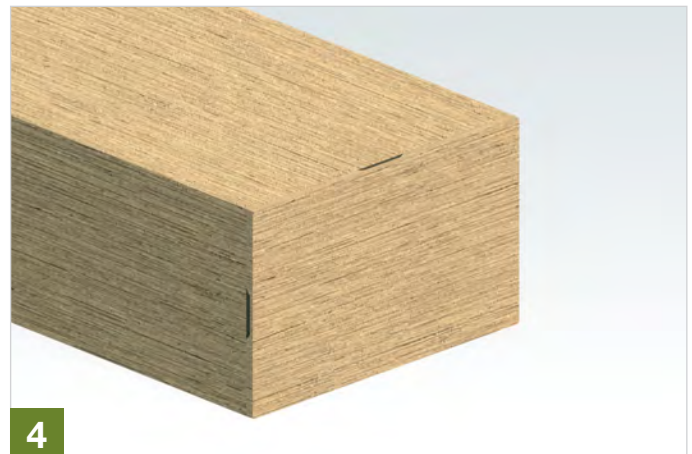

4

The end cap is fixed.

Bending the profiles

- Do not bend the product in environments of 20 degrees Celsius or lower.
- Do not allow the product to reach a temperature exceeding 60 degrees Celsius.
- Do not allow oil, water or other liquids to come into contact with the work.
- Thoroughly wipe away all soiling from the bending machine before starting work.
- Do not use material that has been bent and then re-straightened.

Sanding the profiles

- All profiles are delivered facing the same direction they were sanded in.
- Mount the profiles facing the same direction in order to keep an identical aspect across all profiles.
- Or, mount profiles facing different directions in order to achieve different shades caused by sun beams reflecting from different angles.
- Refer to the marks inside the profiles that indicate the direction of sanding.

Post installation maintenance

- Clear away all cutting dust with an air blower, and make sure the dust does not get caught between products when they are stacked.
- Remove all post-processing burrs with sandpaper.
- Remove all soiling with a neutral detergent such as soap water.
- If a neutral detergent does not successfully remove the soiling, or when differences in luster caused by rubbing exist, use #24 to #40 sandpaper.
- Rub in a single direction (lengthwise) and finish it so that it looks the same as other surfaces.

The Linear Thermal Expansion Coefficient

- The linear thermal expansion coefficient for Geolam profiles is the same as for aluminium: 2.3×10^{-5} mm (20-100°C).
- Geolam profile expansion (per meter) = expansion coefficient x temperature difference (°C) x product length (mm).
- Thus, for a temperature difference of 40°C a Geolam profile expands by 0.92 mm per meter.

Storage

- Do not position the product in an upright position but store it indoors on a flat area.
- Cover the product with a protective sheet if it must be stored outdoors to prevent contact with water.
- However, the product must not be completely sealed-in when covered with a protective sheet.

Geolam, Inc.

North America: 9 Shorncliffe Ave., Toronto, ON Canada M4V 1S9
Toll free: 1-877-627-3530 • Tel: 416-548-7450 • info@geolaminc.com

usa.geolam.com

Technical Data

These profiles exhibit the strength, stability, and versatility of aluminum with the warmth and aesthetic of natural wood. Light and easy to install, this hybrid aluminum/wpc material is used for façade trim, sunshades, screens and other architectural accents.

Soleo 6027



Dimensions	1 ⁵ / ₈ " x 1 ¹ / ₄ " / 40 mm x 30 mm
Weight	0.50 lb/ft / 0.74 kg/ml
End Caps	Yes
Splices/Connectors	No

Soleo 6005



Dimensions	1 ³ / ₄ " x 1" / 45 mm x 25 mm
Weight	0.40 lb/ft / 0.60 kg/ml
End Caps	No
Splices/Connectors	No

Soleo 6008



Dimensions	2" x 1 ¹ / ₄ " / 52 mm x 32 mm
Weight	0.57 lb/ft / 0.85 kg/ml
End Caps	Yes
Splices/Connectors	Yes

Soleo 6029



Dimensions	2 ³ / ₈ " x 1 ¹ / ₄ " / 60 mm x 30 mm
Weight	0.67 lb/ft / 1.00 kg/ml
End Caps	Yes
Splices/Connectors	No

Soleo 6026



Dimensions	2 ³ / ₈ " x 1 ⁵ / ₈ " / 60 mm x 40 mm
Weight	0.71 lb/ft / 1.05 kg/ml
End Caps	Yes
Splices/Connectors	No

Soleo 6011

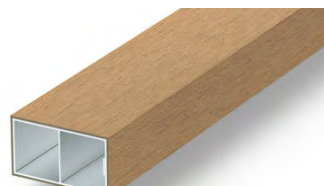

Dimensions	2 ³ / ₄ " x 1 ⁵ / ₈ " / 70 mm x 40 mm
Weight	0.75 lb/ft / 1.12 kg/ml
End Caps	Yes
Splices/Connectors	No

Soleo 6030



Dimensions	3 ¹ / ₈ " x 1 ¹ / ₄ " / 80 mm x 30 mm
Weight	0.81 lb/ft / 1.20 kg/ml
End Caps	Yes
Splices/Connectors	No

Soleo 6017



Dimensions	3 ⁵ / ₈ " x 1 ⁵ / ₈ " / 93 mm x 43 mm
Weight	1.08 lb/ft / 1.60 kg/ml
End Caps	Yes
Splices/Connectors	No

Soleo 6036



Dimensions	4" x 5 ⁵ / ₈ " / 100 mm x 15 mm
Weight	0.67 lb/ft / 1.00 kg/ml
End Caps	No
Splices/Connectors	No

Soleo 6009



Dimensions	4" x 1 ¹ / ₄ " / 100 mm x 30 mm
Weight	0.94 lb/ft / 1.40 kg/ml
End Caps	Yes
Splices/Connectors	No

Soleo 6034



Dimensions	4 ¹ / ₈ " x 2 ¹ / ₈ " / 105 mm x 53 mm
Weight	1.30 lb/ft / 1.94 kg/ml
End Caps	Yes
Splices/Connectors	No

Soleo 6031



Dimensions	5" x 1 ¹ / ₈ " / 126 mm x 28 mm
Weight	1.08 lb/ft / 1.60 kg/ml
End Caps	Yes
Splices/Connectors	Yes

Soleo 6010



Dimensions	5 ¹ / ₈ " x 2 ¹ / ₈ " / 128 mm x 53 mm
Weight	1.55 lb/ft / 2.30 kg/ml
End Caps	Yes
Splices/Connectors	Yes

Soleo 6038

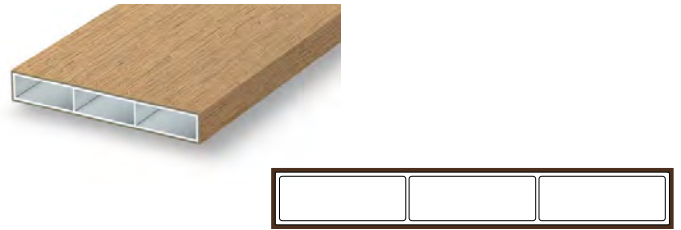

Dimensions	5 ³ / ₄ " x 7 ⁷ / ₈ " / 145 mm x 22 mm
Weight	1.34 lb/ft / 2.00 kg/ml
End Caps	No
Splices/Connectors	No

Soleo 6024

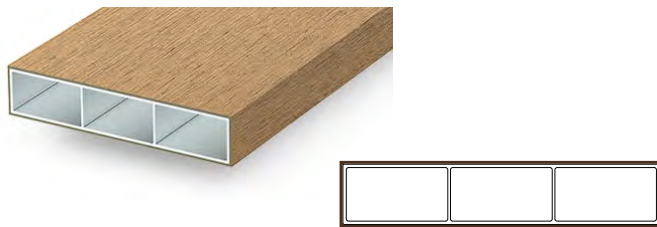

Dimensions	5 ³ / ₄ " x 1 ¹ / ₄ " / 145 mm x 30 mm
Weight	1.38 lb/ft / 2.06 kg/ml
End Caps	No
Splices/Connectors	No

Soleo 6040



Dimensions	6" x 2" / 150 mm x 50 mm
Weight	1.61 lb/ft / 2.40 kg/ml
End Caps	No
Splices/Connectors	No

Soleo 6050



Dimensions	6" x 4" / 150 mm x 100 mm
Weight	2.62 lb/ft / 3.90 kg/ml
End Caps	No
Splices/Connectors	No

Soleo 6033



Dimensions	7 ⁷ / ₈ " x 1 ³ / ₈ " / 200 mm x 35 mm
Weight	2.22 lb/ft / 3.30 kg/ml
End Caps	Yes
Splices/Connectors	Yes

Planeo 4010

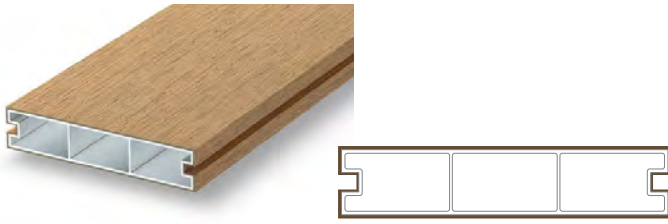

Dimensions	145 mm x 30 mm / 5 ³ / ₄ " x 1 ¹ / ₄ "
Weight	2.21 kg/ml / 1.49 lb/ft
End Caps	No
Splices/Connectors	No

Planeo 4044*

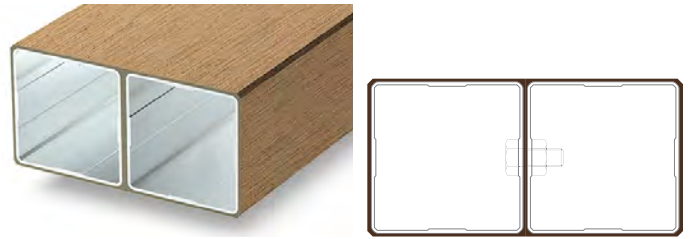

Dimensions	6 ⁷ / ₈ " x 3 ³ / ₈ " / 174 mm x 87 mm
Weight	3.04 lb/ft / 4.52 kg/ml
End Caps	No
Splices/Connectors	No

Planeo 4123*

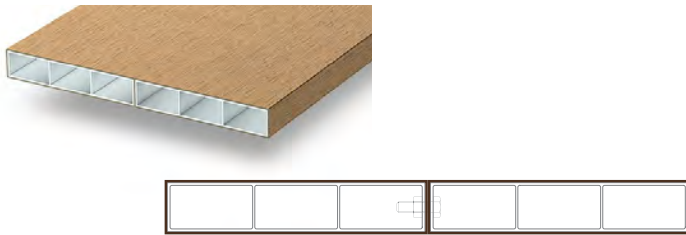

Dimensions	11 ³ / ₈ " x 1 ³ / ₈ " / 290 mm x 30 mm
Weight	2.51 lb/ft / 3.74 kg/ml
End Caps	No
Splices/Connectors	No

Planeo 4048*

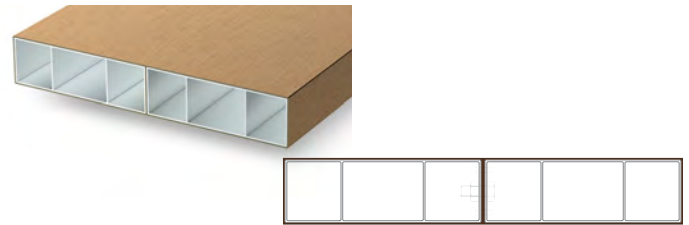

Dimensions	11 ³ / ₄ " x 2" / 300 mm x 50 mm
Weight	3.23 lb/ft / 4.80 kg/ml
End Caps	No
Splices/Connectors	No

Planeo 4061*

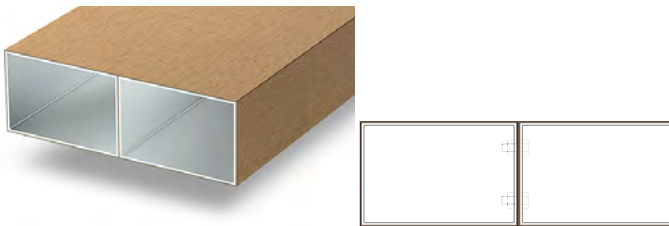

Dimensions	11 ³ / ₄ " x 4" / 300 mm x 100 mm
Weight	6.38 lb/ft / 9.50 kg/ml
End Caps	No
Splices/Connectors	No

Planeo 4046*

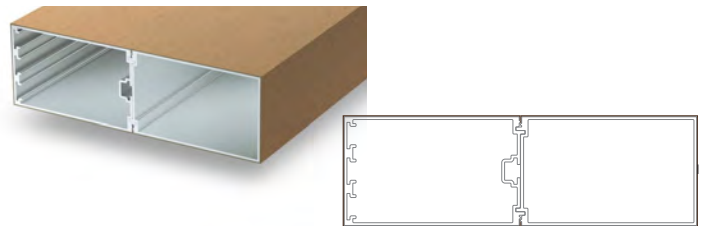

Dimensions	13 ³ / ₄ " x 4 ¹ / ₄ " / 350 mm x 110 mm
Weight	6.65 lb/ft / 9.90 kg/ml
End Caps	No
Splices/Connectors	No

* Planeo boards cannot be cut within the bolts at either board end. Refer to Architectural Elements Installation Guide for more details.

Planeo 4062*

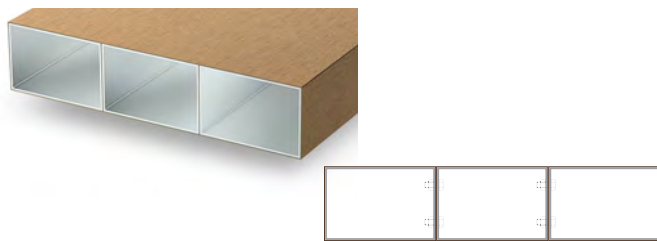

Dimensions	17 ³ / ₄ " x 4" / 450 mm x 100 mm
Weight	9.58 lb/ft / 14.25 kg/ml
End Caps	No
Splices/Connectors	No

Diameo 2018



Dimensions	4 ³ / ₄ " x 1 ¹ / ₄ " / 120 mm x 30 mm
Weight	0.95 lb/ft / 1.42 kg/ml
End Caps	Yes
Splices/Connectors	Yes

Diameo 2023

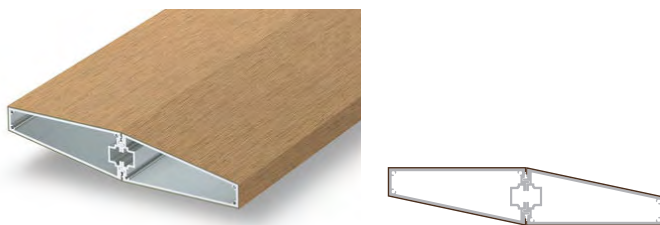

Dimensions	11 ³ / ₄ " x 2 ³ / ₈ " / 60 mm x 300 mm
Weight	4.99 lb/ft / 7.43 kg/ml
End Caps	No
Splices/Connectors	No

Careo 7010



Dimensions	1 ³ / ₄ " x 1 ³ / ₄ " / 44 mm x 44 mm
Weight	0.50 lb/ft / 0.74 kg/ml
End Caps	No
Splices/Connectors	No

Careo 7031



Dimensions	1 ³ / ₄ " x 1 ³ / ₄ " / 45 mm x 45 mm
Weight	0.55 lb/ft / 0.82 kg/ml
End Caps	No
Splices/Connectors	No

Careo 7011



Dimensions	2 ¹ / ₈ " x 2 ¹ / ₈ " / 53 mm x 53 mm
Weight	0.90 lb/ft / 1.34 kg/ml
End Caps	No
Splices/Connectors	Yes

* Planeo boards cannot be cut within the bolts at either board end. Refer to Architectural Elements Installation Guide for more details.

Careo 7035

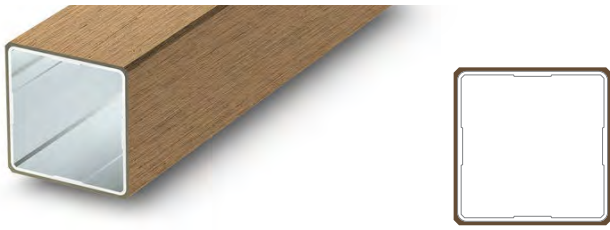

Dimensions	$3\frac{3}{8}'' \times 3\frac{3}{8}''$ / 87 mm x 87 mm
Weight	1.53 lb/ft / 2.28 kg/ml
End Caps	No
Splices/Connectors	No

Careo 7014



Dimensions	$3\frac{1}{2}'' \times 3\frac{1}{2}''$ / 88 mm x 88 mm
Weight	1.88 lb/ft / 2.80 kg/ml
End Caps	Yes
Splices/Connectors	No

Careo 7016



Dimensions	$4\frac{3}{4}'' \times 4\frac{3}{4}''$ / 120 mm x 120 mm
Weight	2.69 lb/ft / 4.00 kg/ml
End Caps	No
Splices/Connectors	No

END CAPS Hybrid aluminum/wpc



The end caps have to be glued to the profile.
They have four openings to allow for weeping of condensation – these must not be blocked.
For a perfect aesthetic, wood composite end caps (WPC) can be adapted in size to the profile or showcased by an appropriate sanding.

SPLICERS/CONNECTORS Hybrid aluminum/wpc

Corners

Française (Lying Down) Belge (Standing Up)

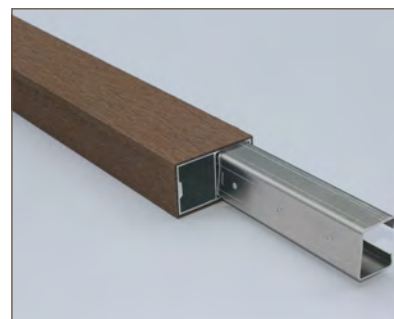
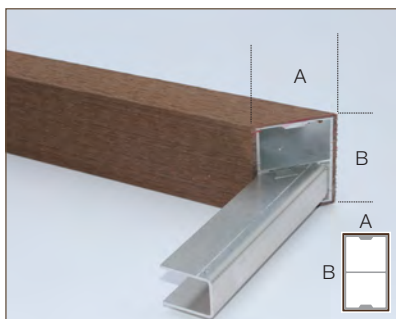
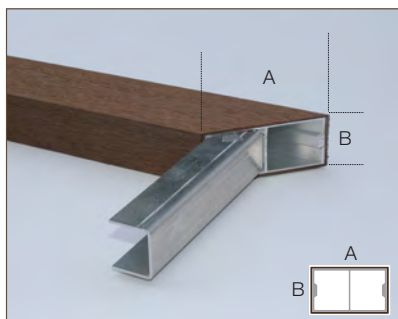

Straight

Note: bumps to prevent sliding during installation



SPAN CHARTS

Façades, Sunshades, Screens and
Other Architectural Elements

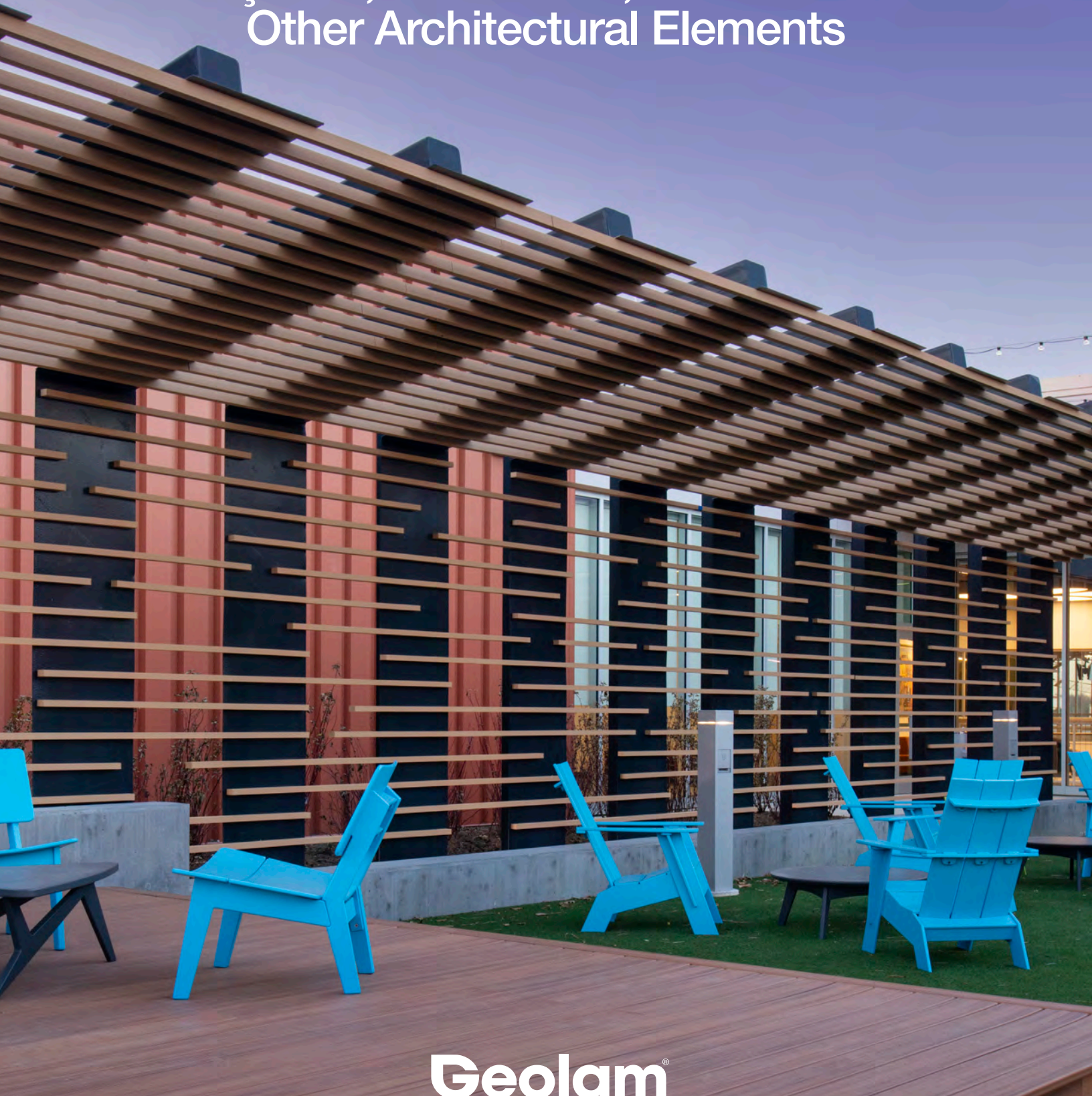

Merriam Community Center, Merriam, KS
Soleo 6008 - Teak

Geolam[®]
Architectural Eco-Technology

info@geolaminc.com
usa.geolam.com

Notes

1. These charts account for wind loads only.
2. Based on a deflection limit of $L/120$ (International Building Code 2015)
3. Suggested length for a cantilever installation is half of the length displayed on the chart.
4. These charts do not account for increased wind load at building corners. Suggested span length should be decreased in these areas. Contact a design professional for details.
5. Charts to be used for estimating purposes only. Contact a design professional to determine specific code/specification compliance.

Soleo 6027

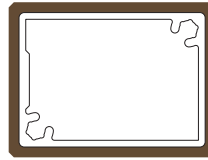

Dimensions	1 ⁵ / ₈ " x 1 ¹ / ₄ " / 40 mm x 30 mm
Weight	0.50 lb/ft / 0.74 kg/ml
End Caps	Yes
Splices/Connectors	No

Span length for wind on wide side

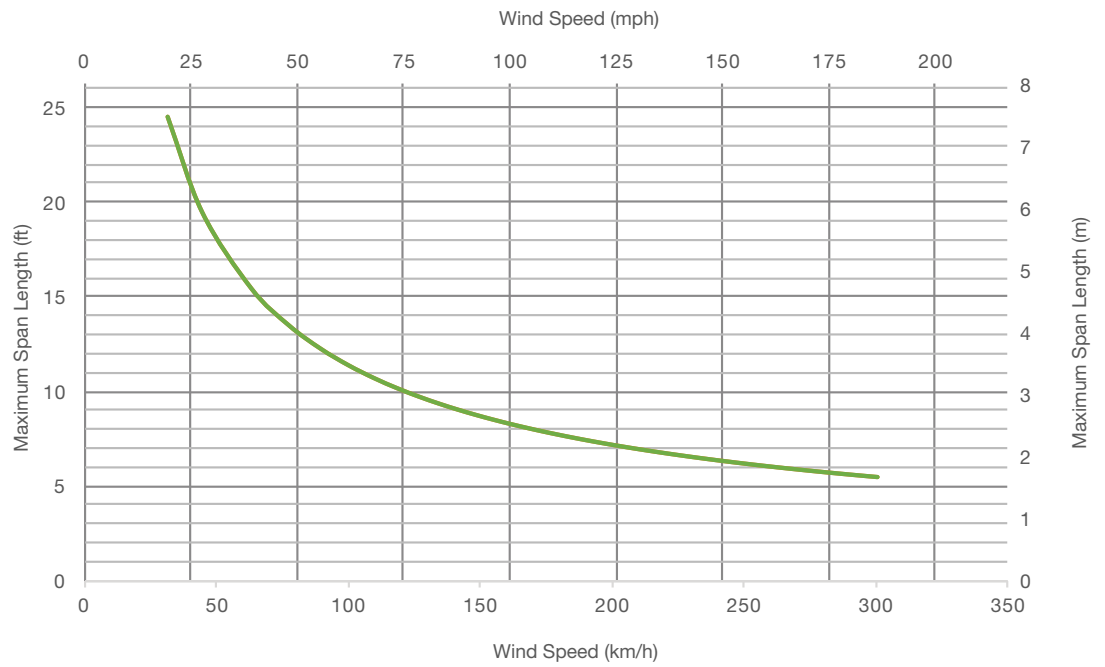
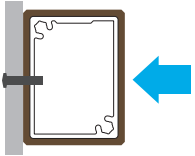

Span length for wind on narrow side

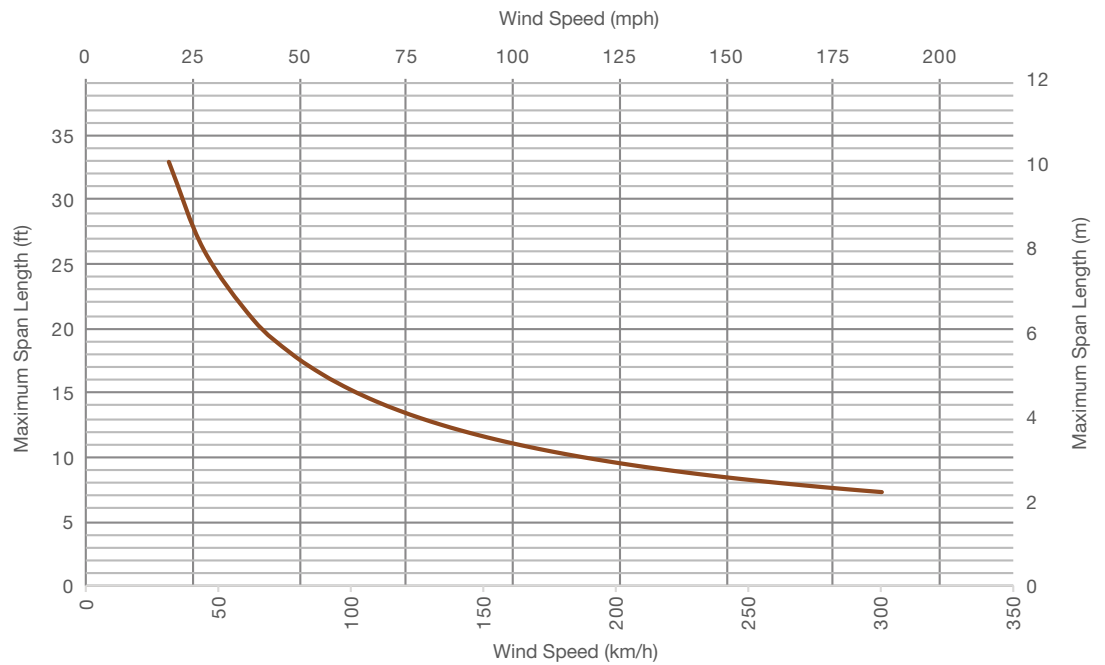
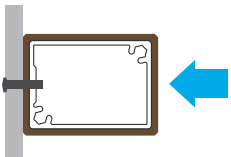

Soleo 6005

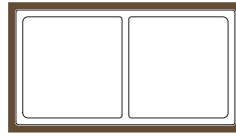

Dimensions	1 ³ / ₄ " x 1" / 45 mm x 25 mm
Weight	0.40 lb/ft / 0.60 kg/ml
End Caps	No
Splices/Connectors	No

Span length for wind on wide side

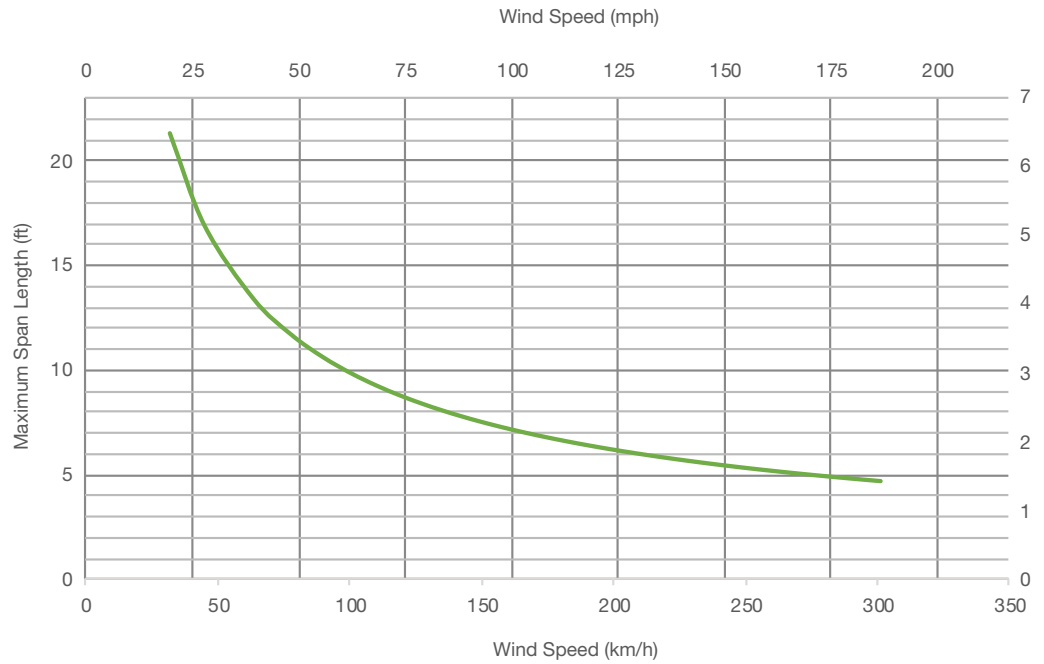
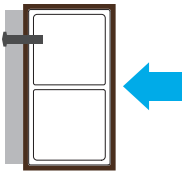

Span length for wind on narrow side

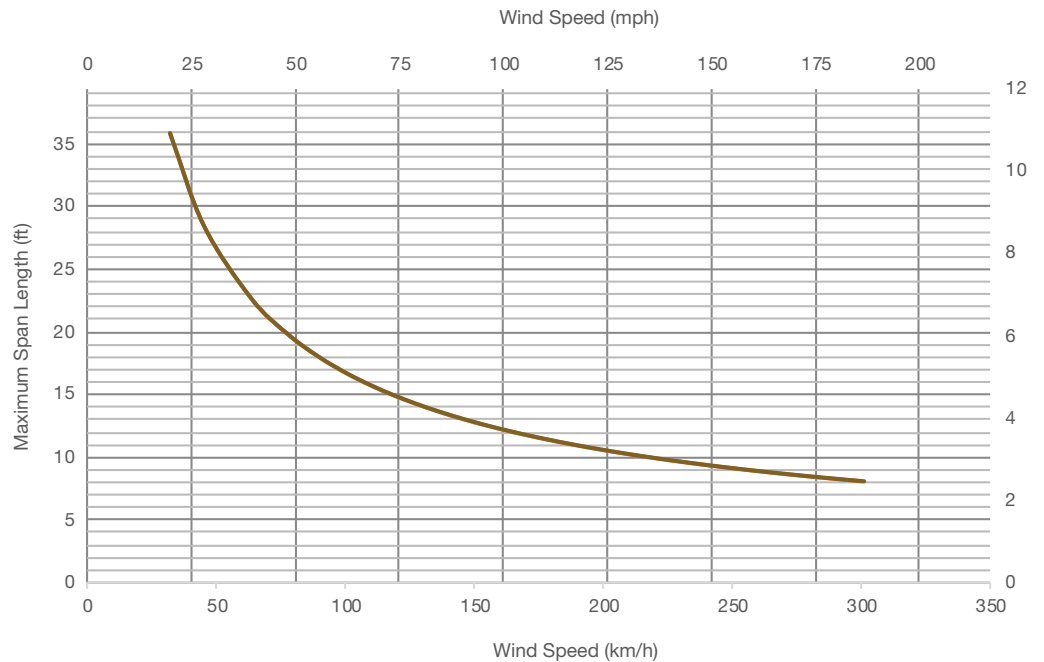
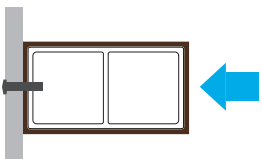

Soleo 6008

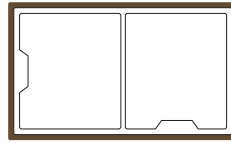

Dimensions	2" x 1 1/4" / 52 mm x 32 mm
Weight	0.57 lb/ft / 0.85 kg/ml
End Caps	Yes
Splices/Connectors	Yes

Span length for wind on wide side

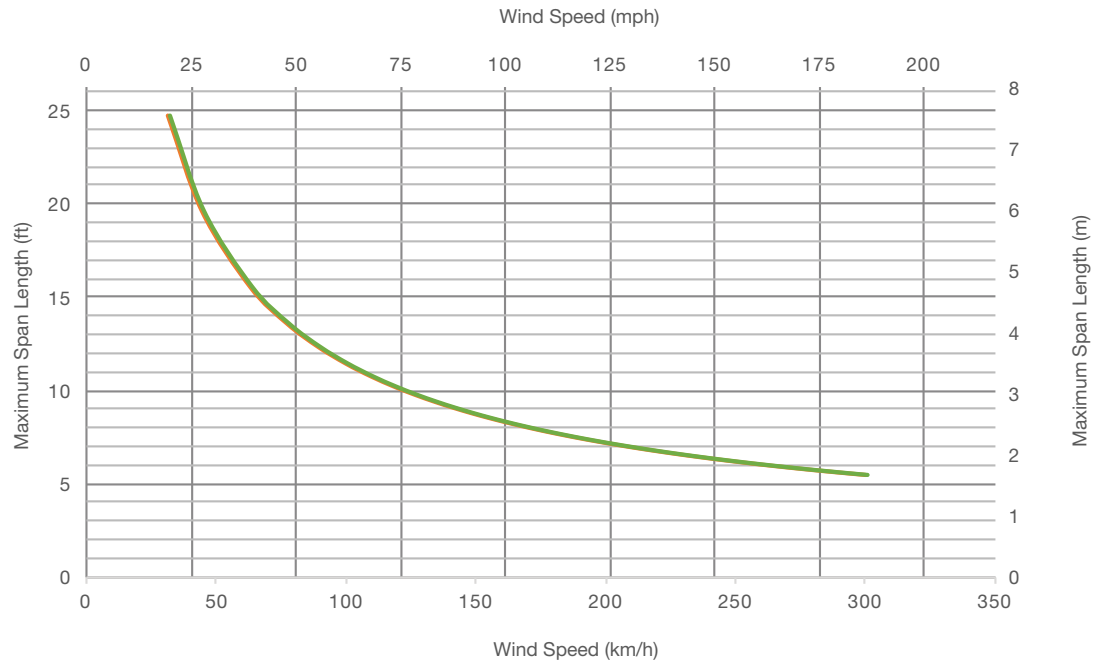
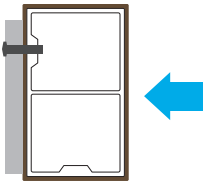

Span length for wind on narrow side

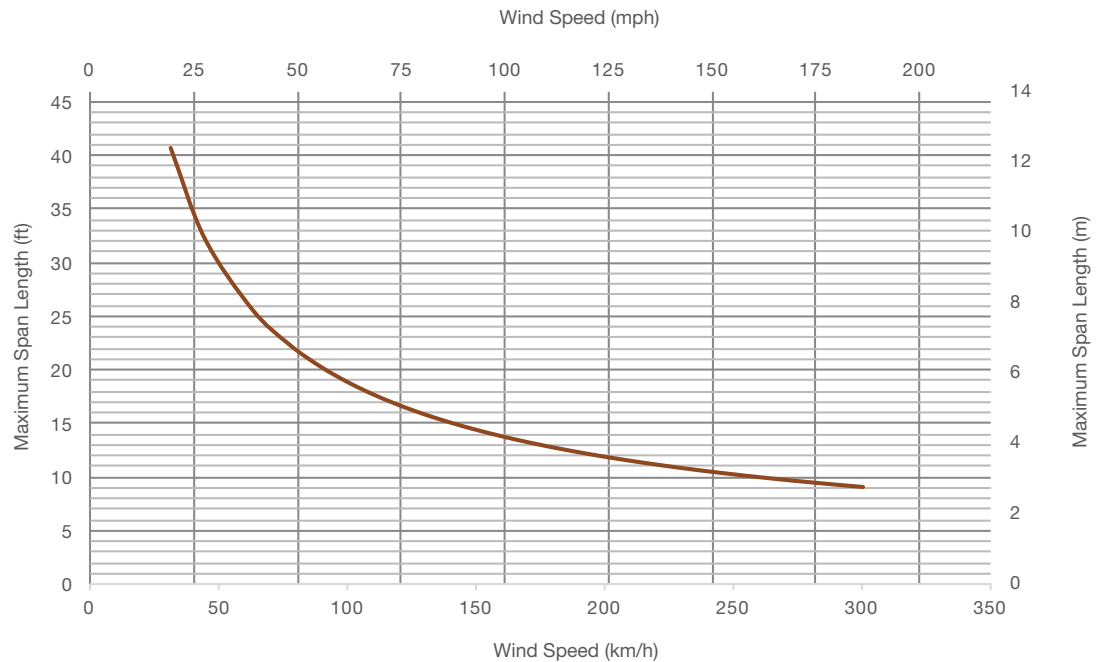
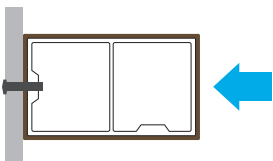

Soleo 6029

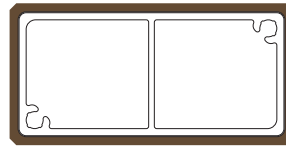

Dimensions	2 ³ / ₈ " x 1 ¹ / ₄ " / 60 mm x 30 mm
Weight	0.67 lb/ft / 1.00 kg/ml
End Caps	Yes
Splices/Connectors	No

Span length for wind on wide side

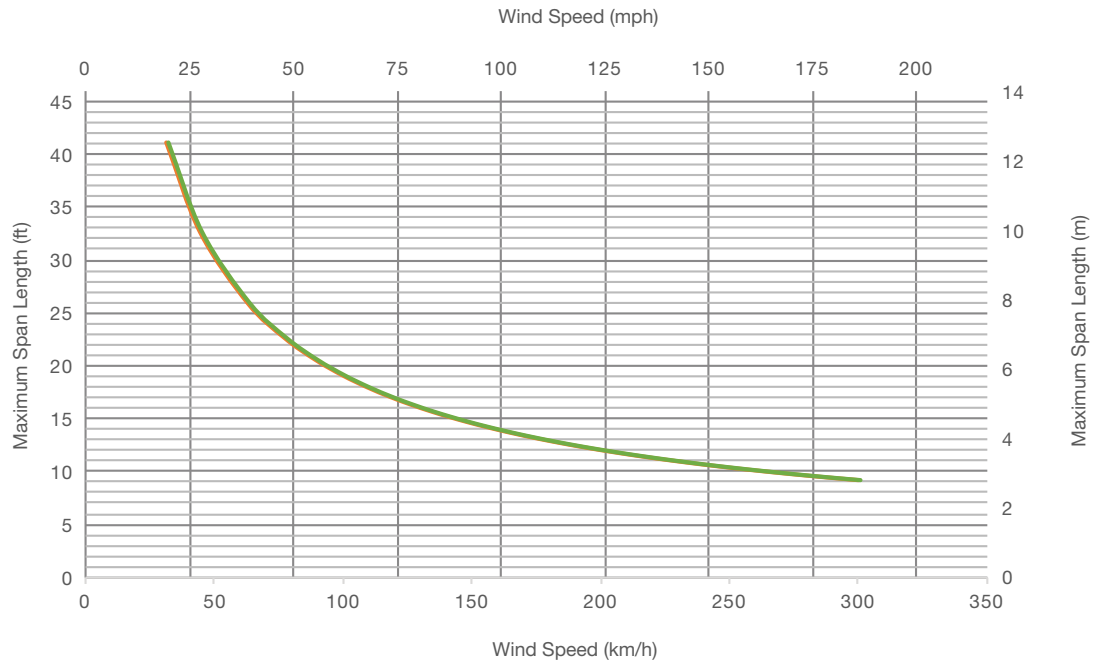
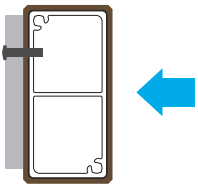

Span length for wind on narrow side

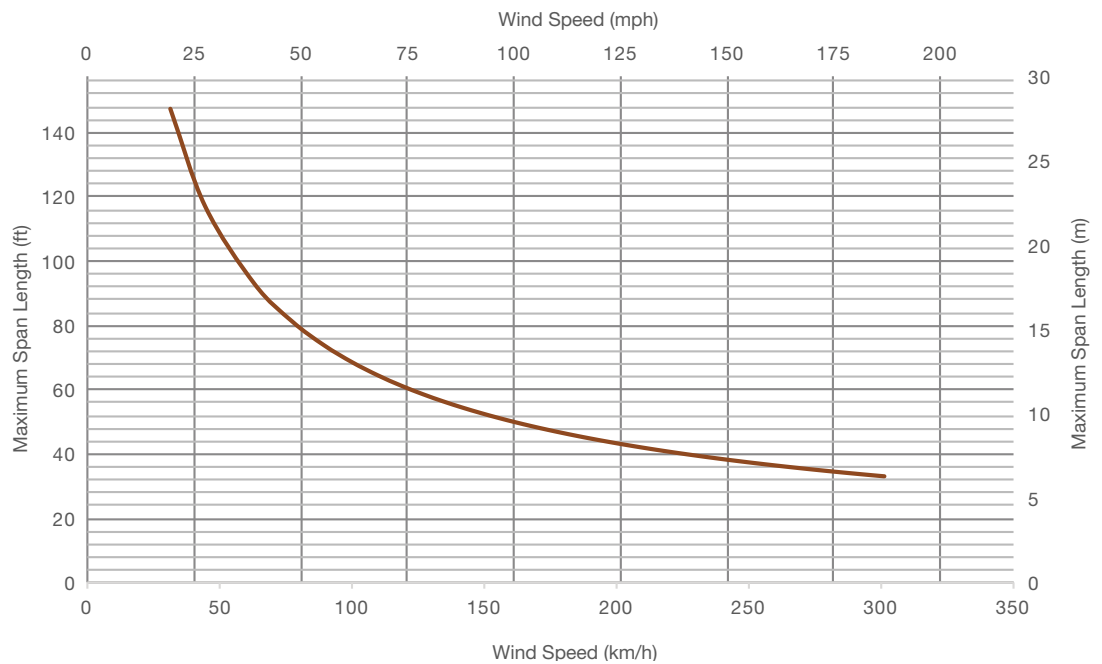
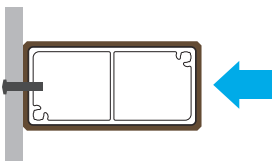

Soleo 6026

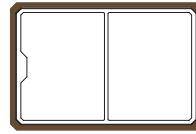

Dimensions	2 ³ / ₈ " x 1 ⁵ / ₈ " / 60 mm x 40 mm
Weight	0.71 lb/ft / 1.05 kg/ml
End Caps	Yes
Splices/Connectors	No

Span length for wind on wide side

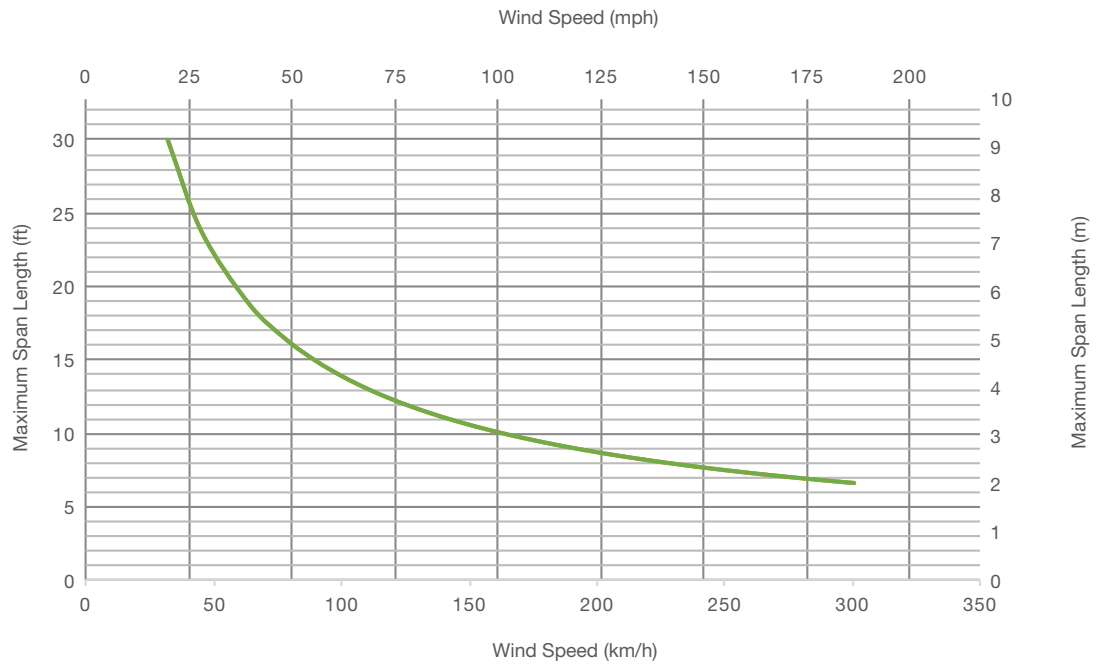
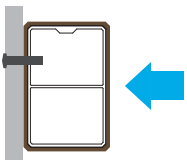

Span length for wind on narrow side

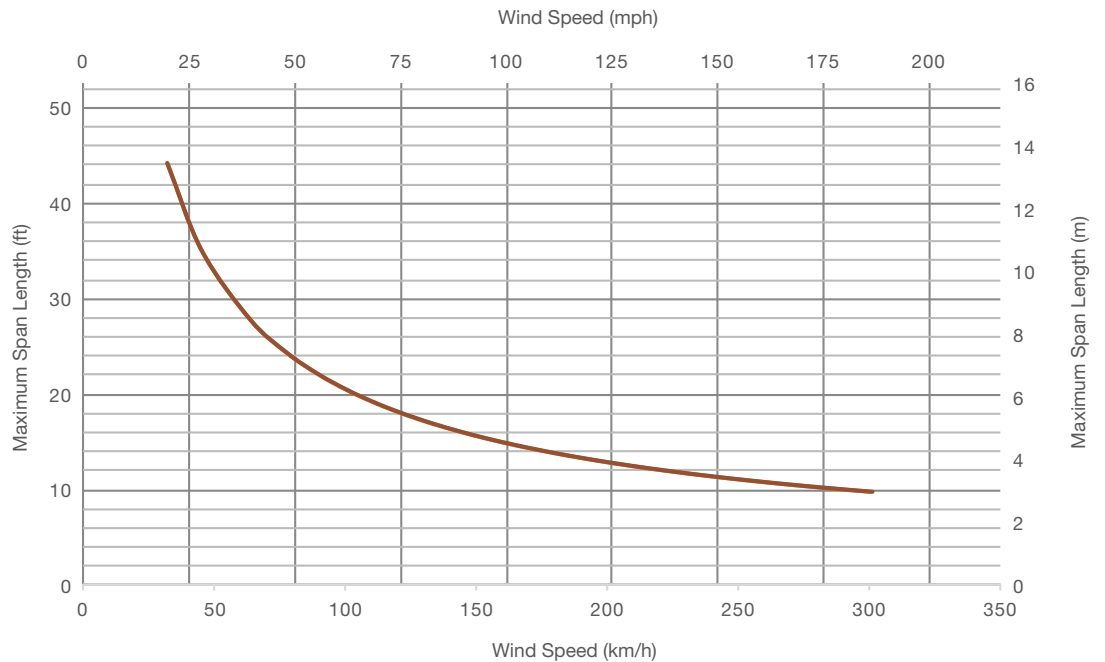
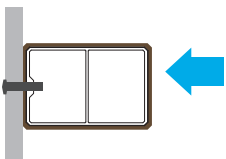

Soleo 6011

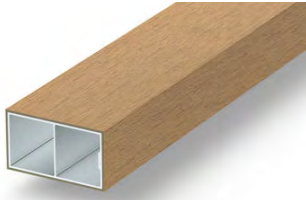

Dimensions	2 ³ / ₄ " x 1 ⁵ / ₈ " / 70 mm x 40 mm
Weight	0.75 lb/ft / 1.12 kg/ml
End Caps	Yes
Splices/Connectors	No

Span length for wind on wide side

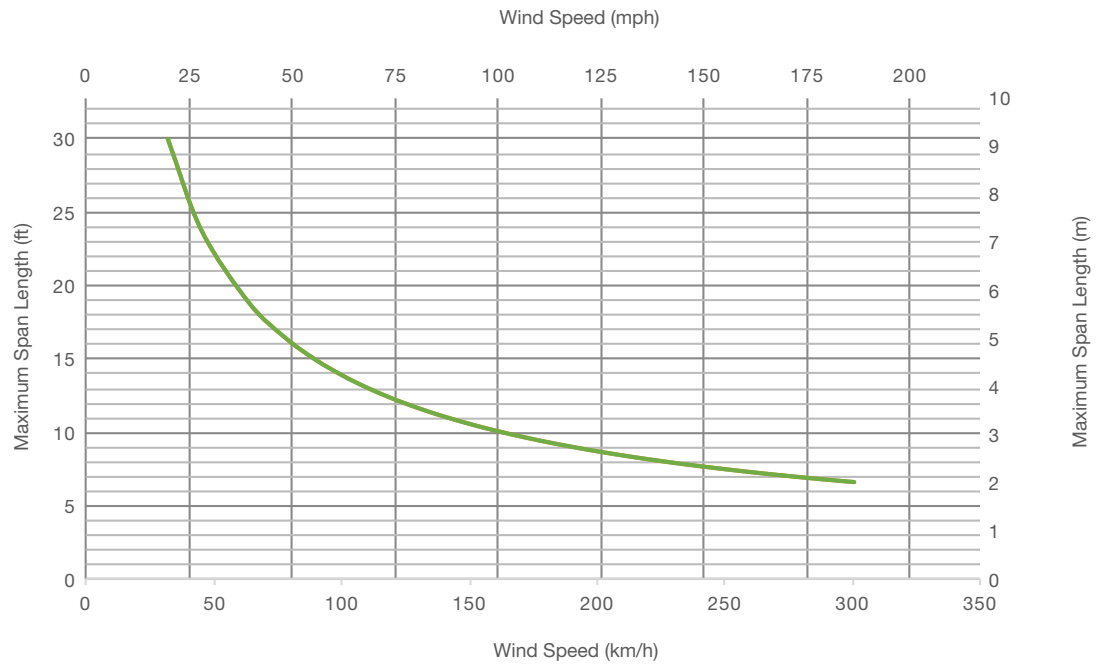
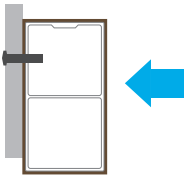

Span length for wind on narrow side

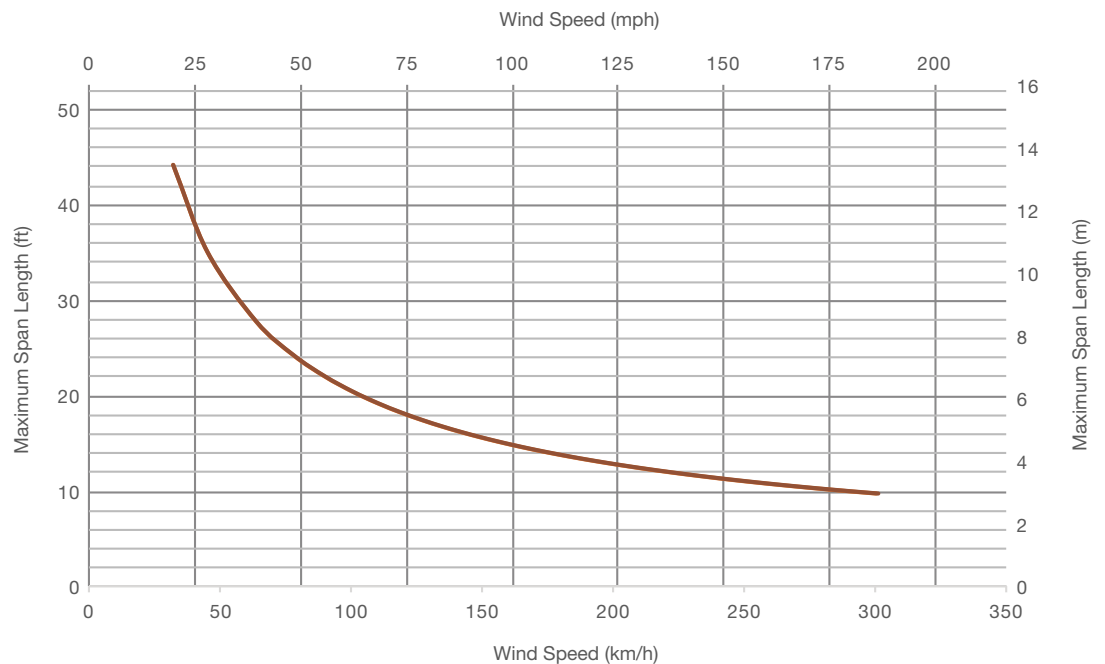
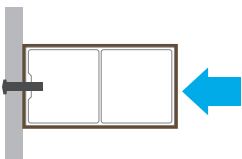

Soleo 6030

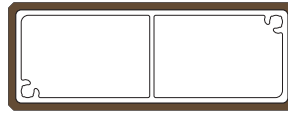

Dimensions	3 1/8" x 1 1/4" / 80 mm x 30 mm
Weight	0.81 lb/ft / 1.20 kg/ml
End Caps	Yes
Splices/Connectors	No

Span length for wind on wide side

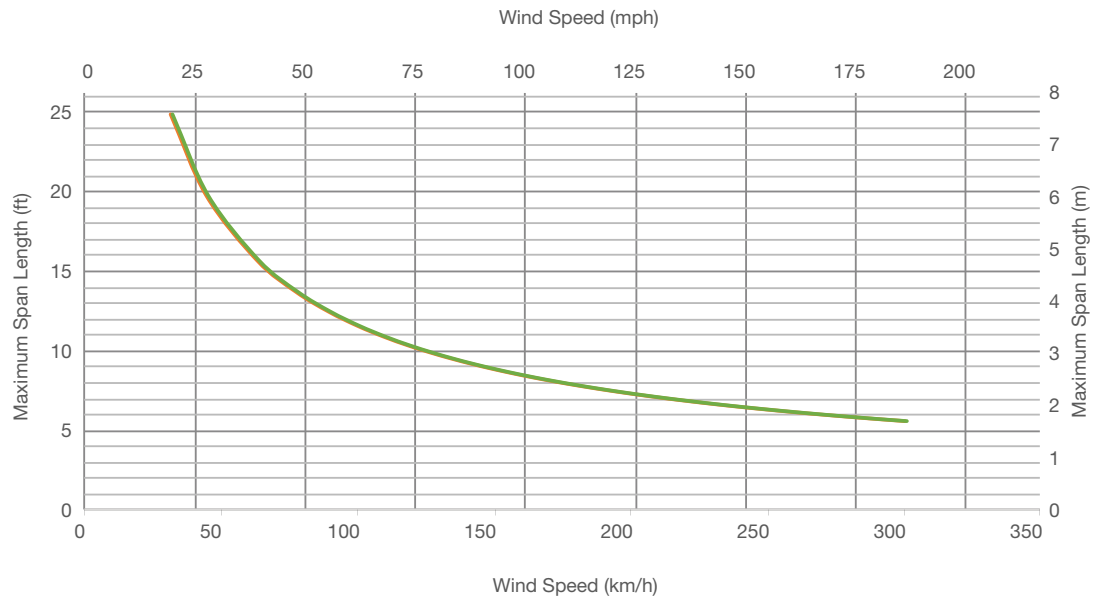
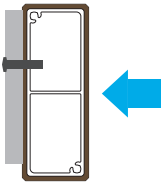

Span length for wind on narrow side

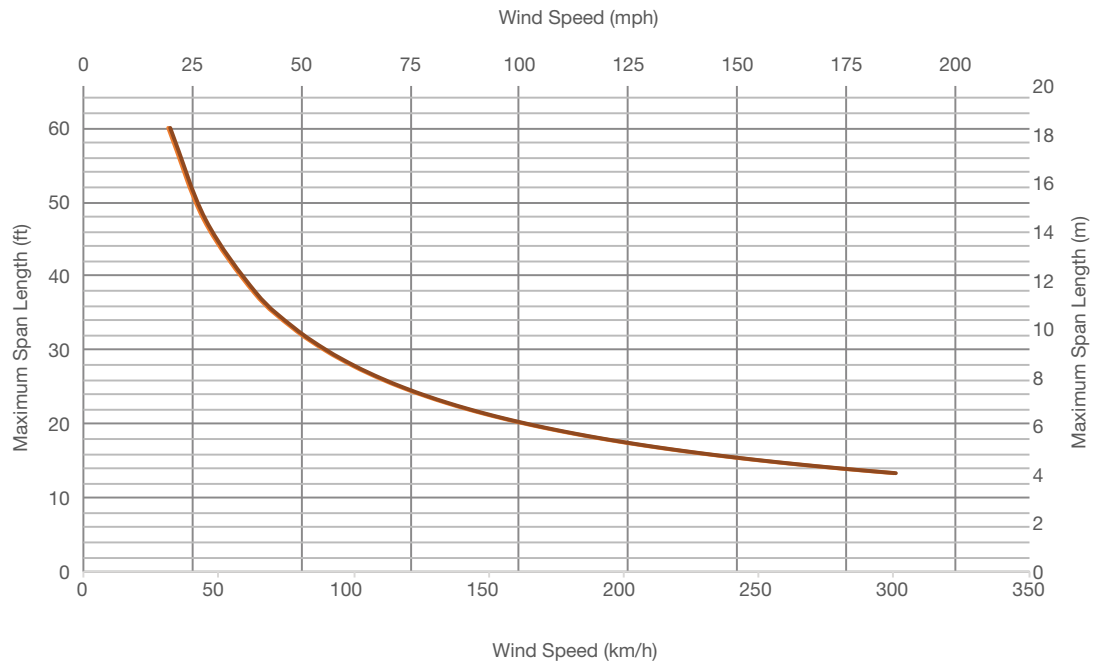
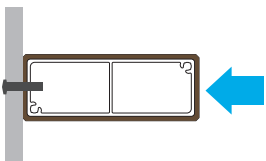

Soleo 6017

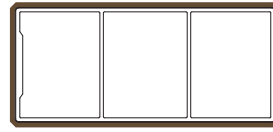

Dimensions	3 ⁵ / ₈ " x 1 ⁵ / ₈ " / 93 mm x 43 mm
Weight	1.08 lb/ft / 1.60 kg/ml
End Caps	Yes
Splices/Connectors	No

Span length for wind on wide side

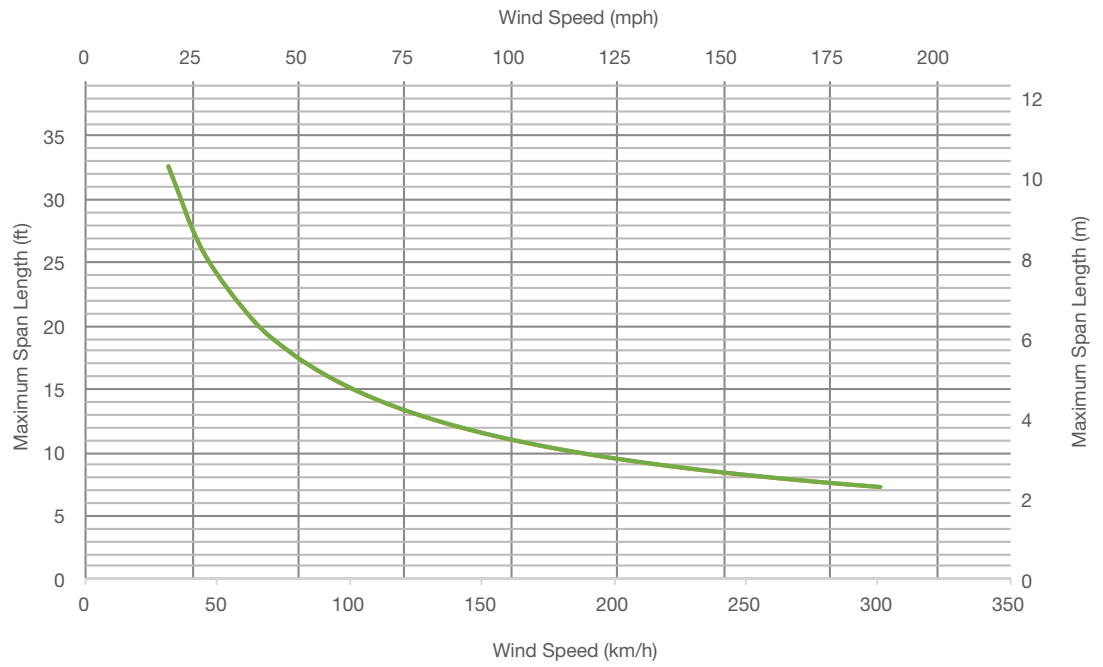
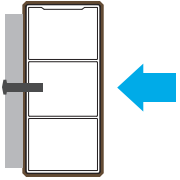

Span length for wind on narrow side

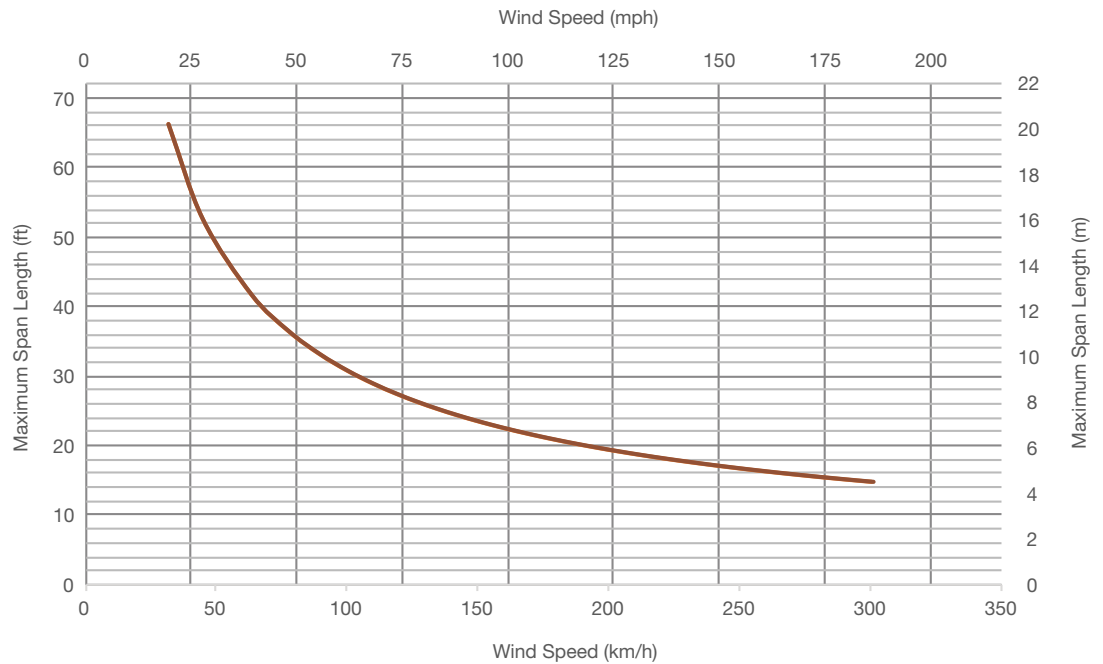
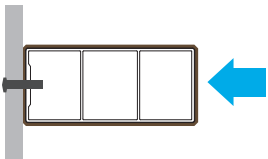

Soleo 6036



Dimensions	4" x 5/8" / 100 mm x 15 mm
Weight	0.67 lb/ft / 1.00 kg/ml
End Caps	No
Splices/Connectors	No

Span length for wind on wide side

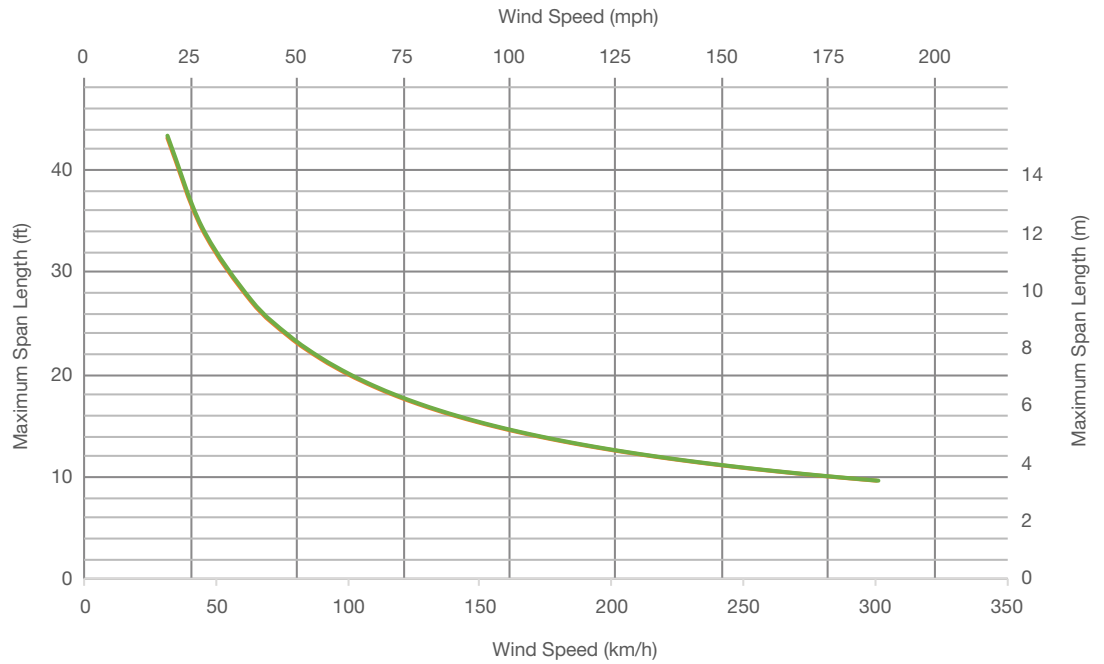
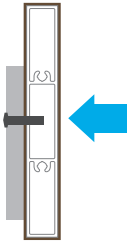

Span length for wind on narrow side

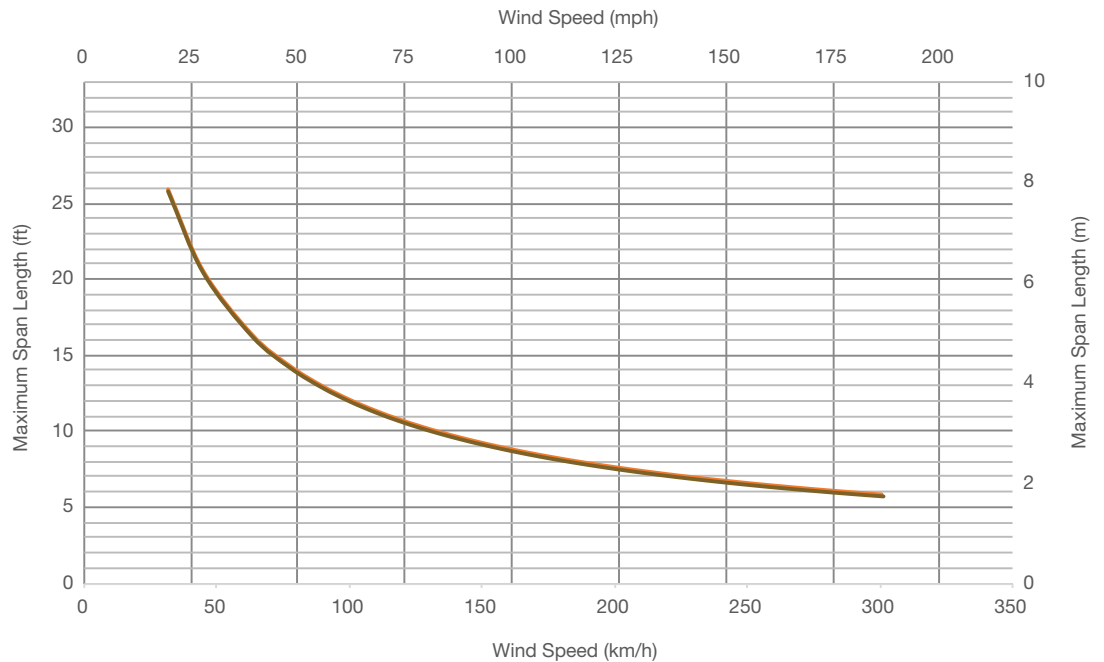
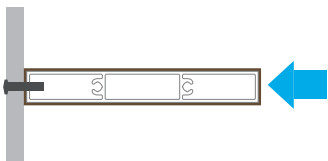

Soleo 6009

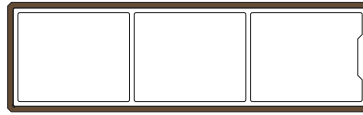

Dimensions	4" x 1 1/4" / 100 mm x 30 mm
Weight	0.94 lb/ft / 1.40 kg/ml
End Caps	Yes
Splices/Connectors	No

Span length for wind on wide side

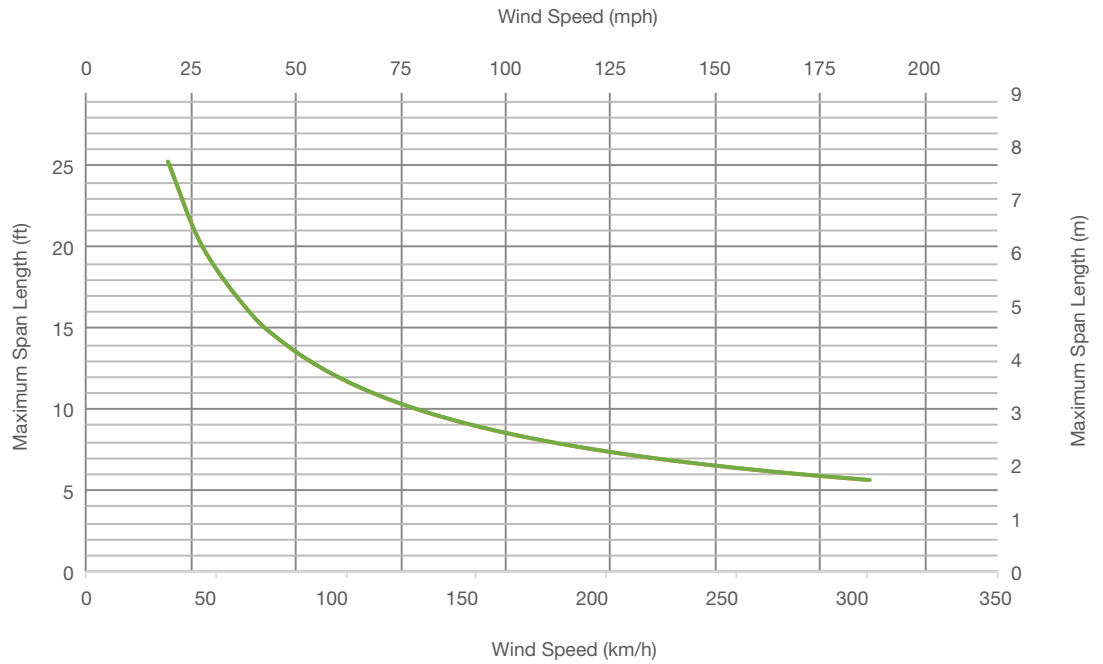
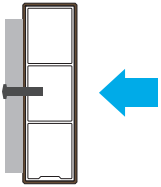

Span length for wind on narrow side

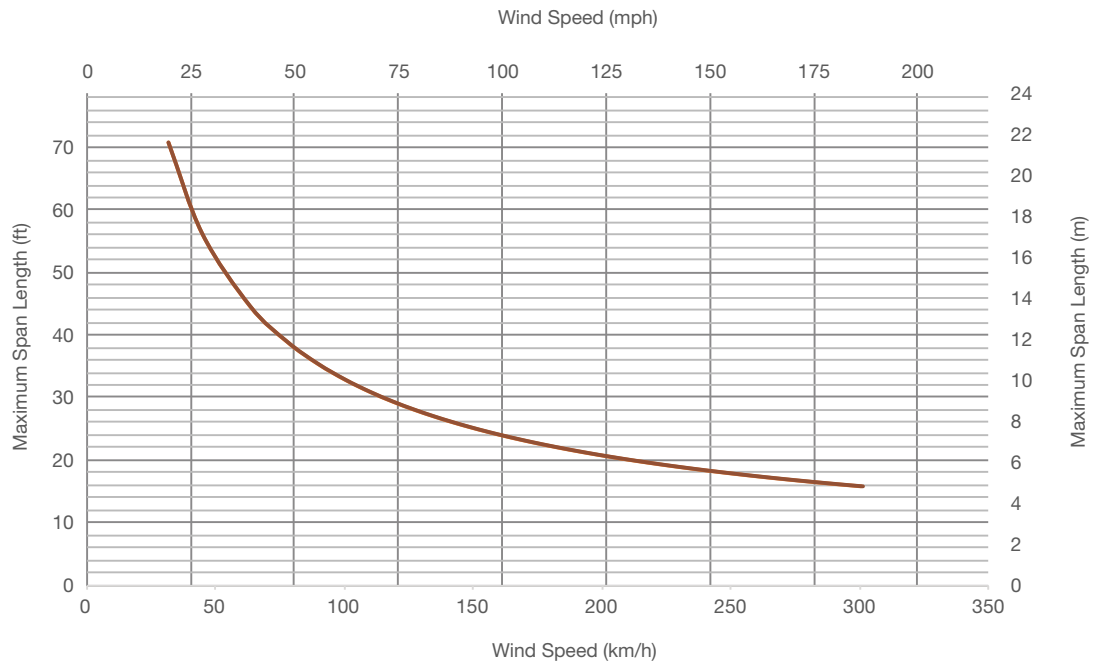
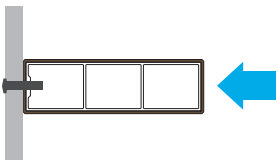

Soleo 6034

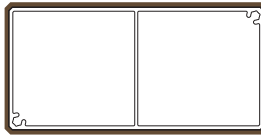

Dimensions	4 ¹ / ₈ " x 2 ¹ / ₈ " / 105 mm x 53 mm
Weight	1.30 lb/ft / 1.94 kg/ml
End Caps	Yes
Splices/Connectors	No

Span length for wind on wide side

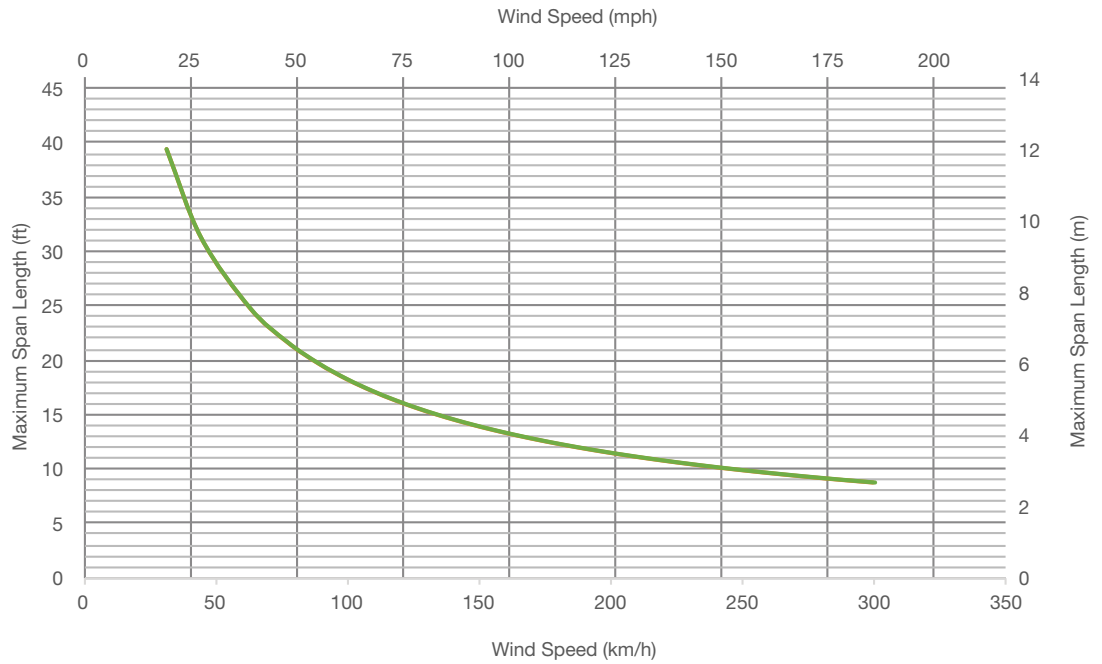
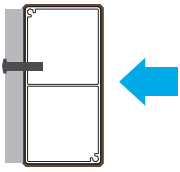

Span length for wind on narrow side

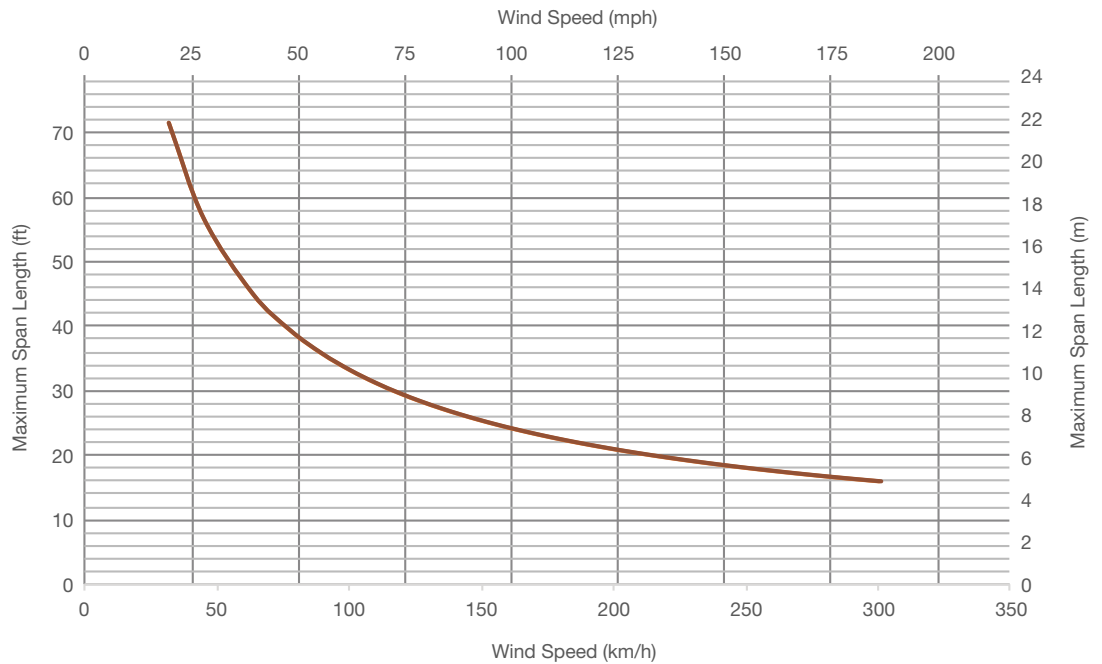
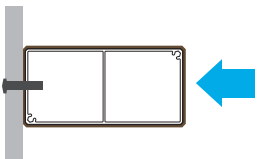

Soleo 6031



Dimensions	5" x 1 1/8" / 126 mm x 28 mm
Weight	1.08 lb/ft / 1.60 kg/ml
End Caps	Yes
Splices/Connectors	Yes

Span length for wind on wide side

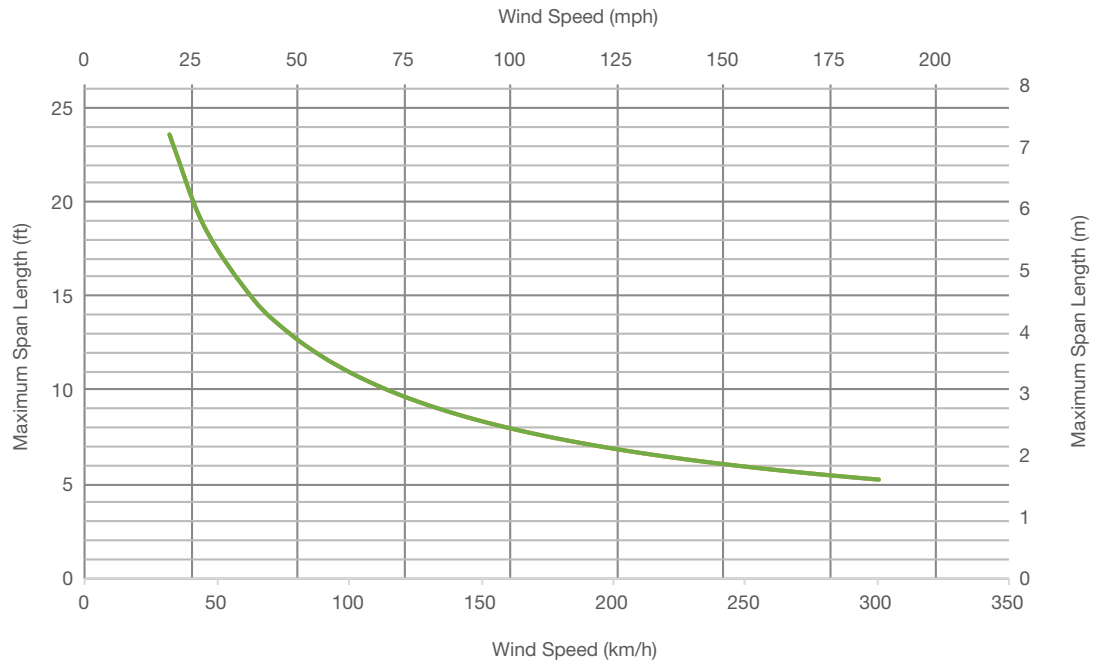
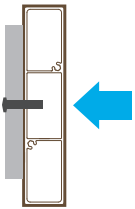

Span length for wind on narrow side

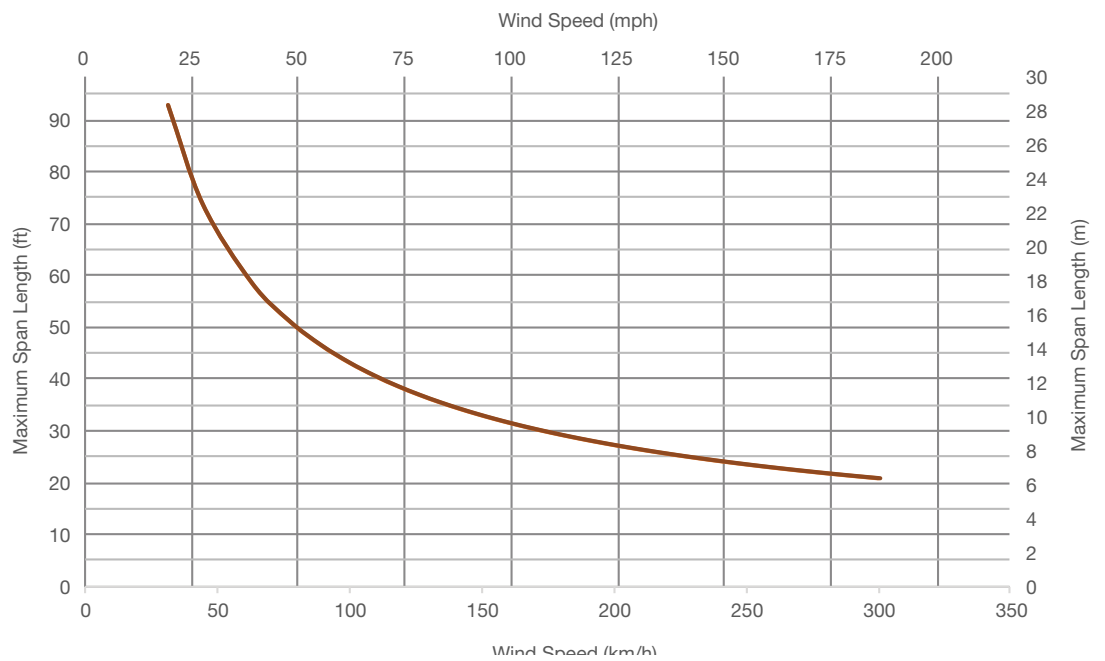
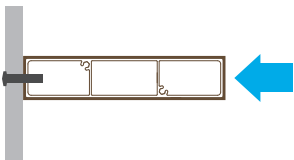

Soleo 6010

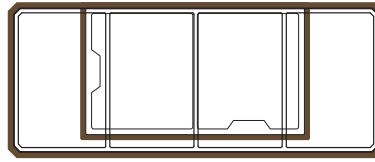

Dimensions	5 ¹ / ₈ " x 2 ¹ / ₈ " / 128 mm x 53 mm
Weight	1.55 lb/ft / 2.30 kg/ml
End Caps	Yes
Splices/Connectors	Yes

Span length for wind on wide side

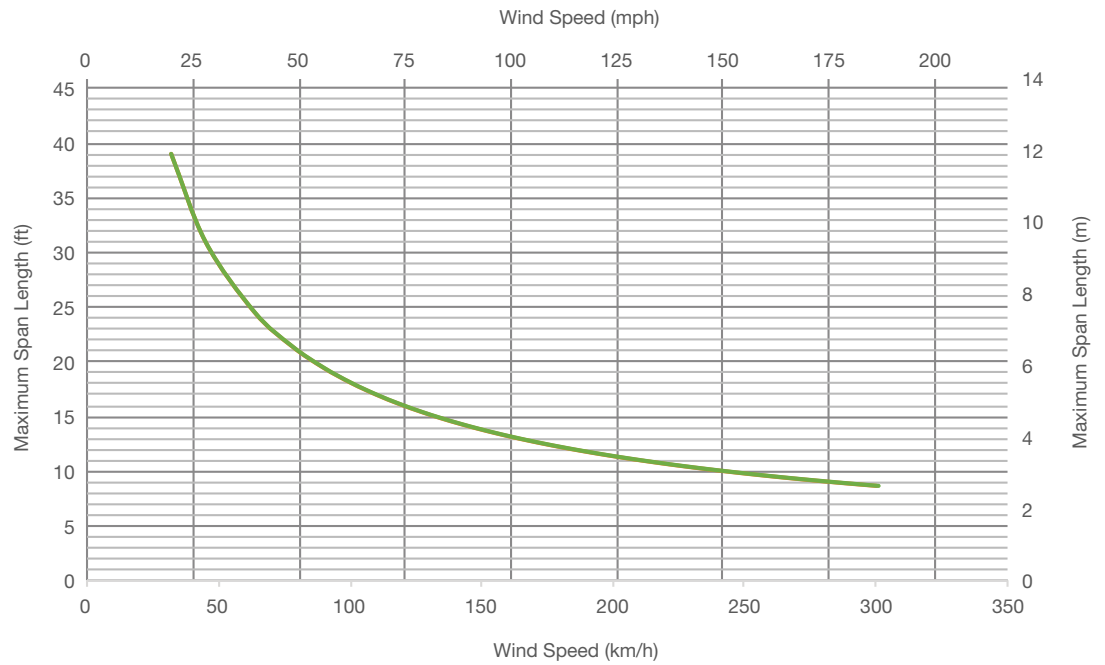
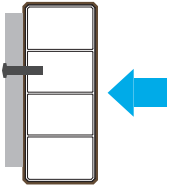

Span length for wind on narrow side

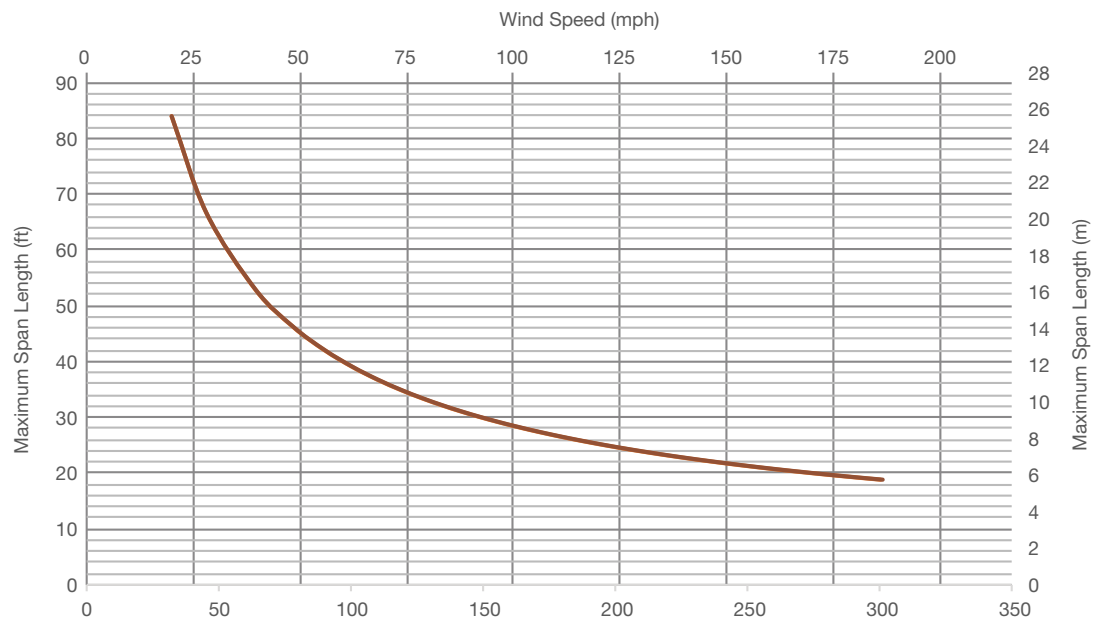
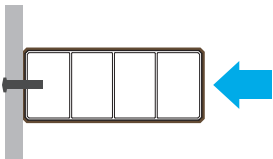

Soleo 6038



Dimensions	5 ³ / ₄ " x 7 ⁷ / ₈ " / 145 mm x 22 mm
Weight	1.34 lb/ft / 2.00 kg/ml
End Caps	No
Splices/Connectors	No

Span length for wind on wide side

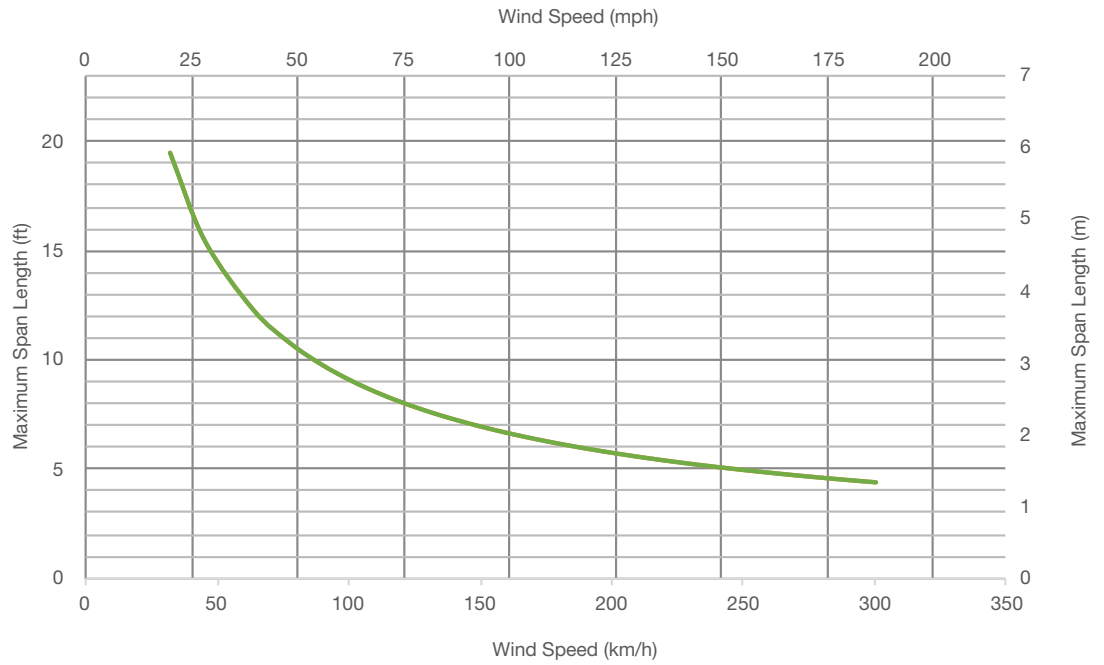
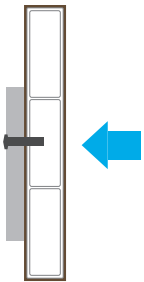

Span length for wind on narrow side

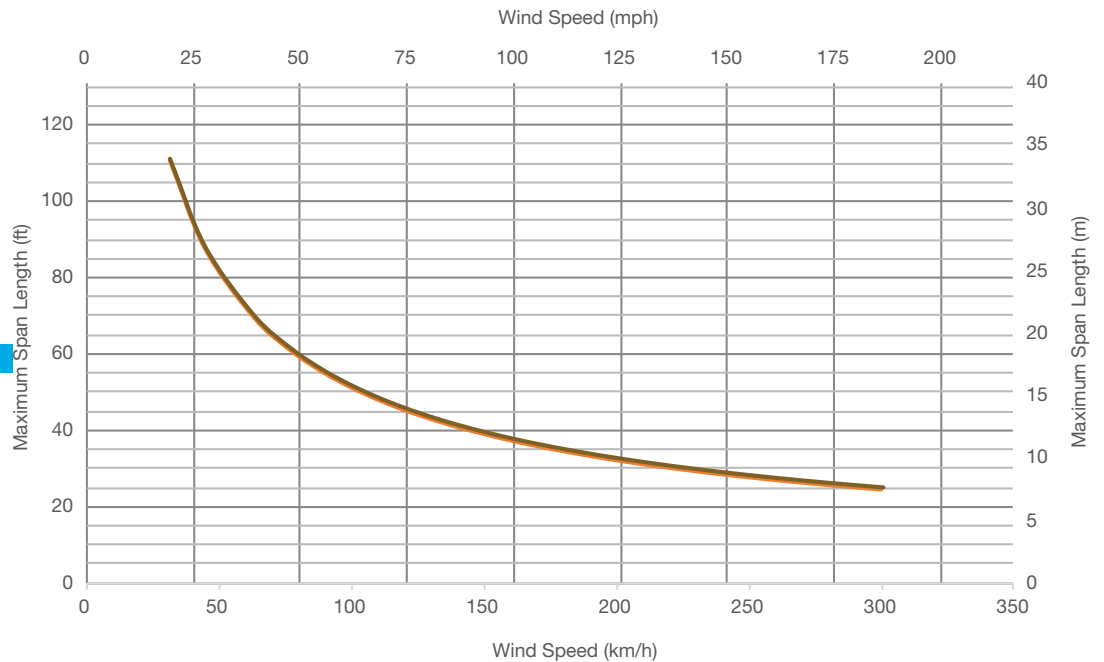
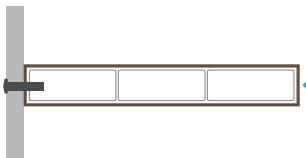

Soleo 6024



Dimensions	5 ³ / ₄ " x 1 ¹ / ₄ " / 145 mm x 30 mm
Weight	1.38 lb/ft / 2.06 kg/ml
End Caps	No
Splices/Connectors	No

Span length for wind on wide side

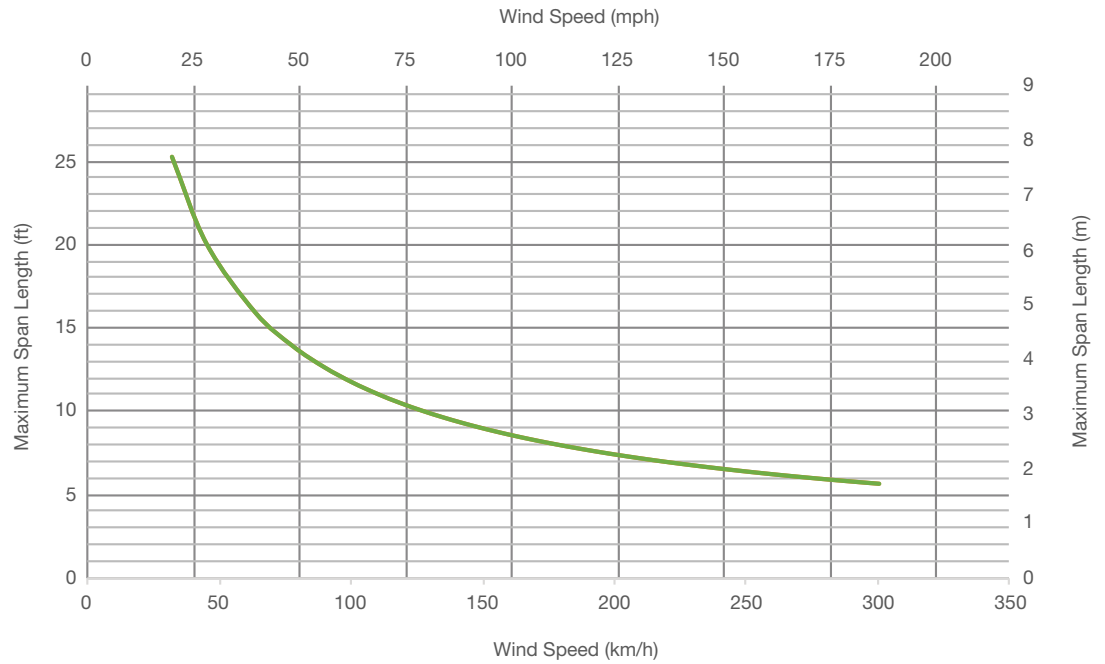
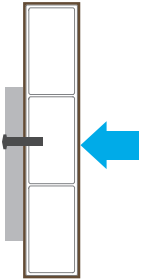

Span length for wind on narrow side

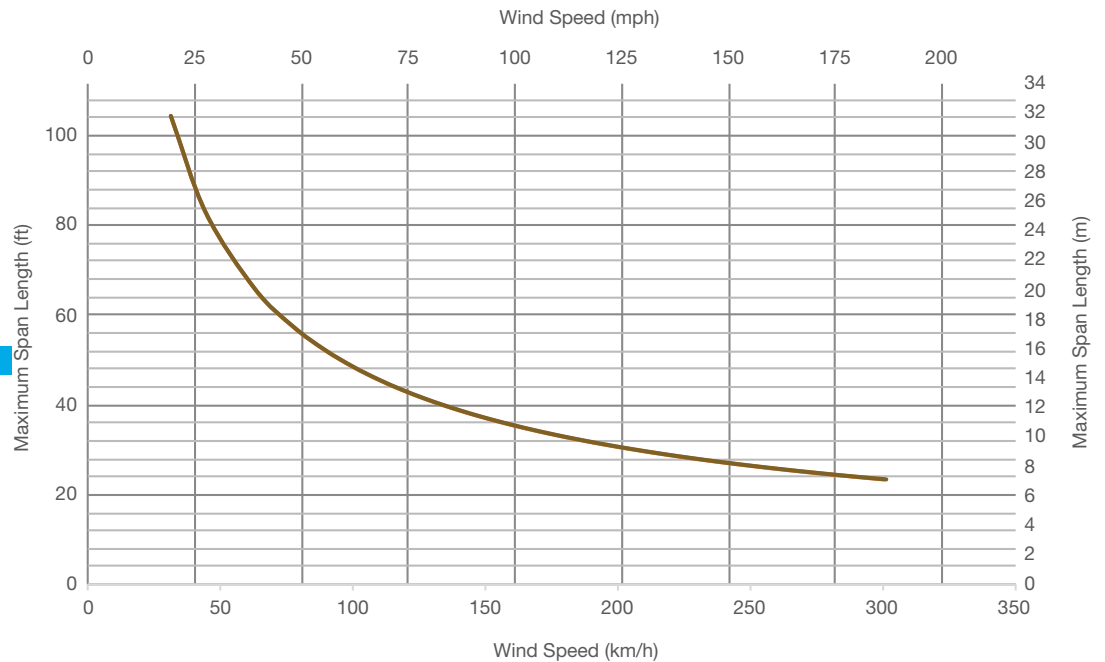
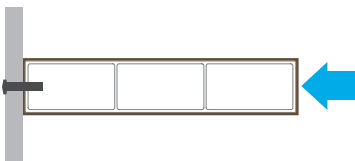

Soleo 6040



Dimensions	6" x 2" / 150 mm x 50 mm
Weight	1.61 lb/ft / 2.40 kg/ml
End Caps	No
Splices/Connectors	No

Span length for wind on wide side

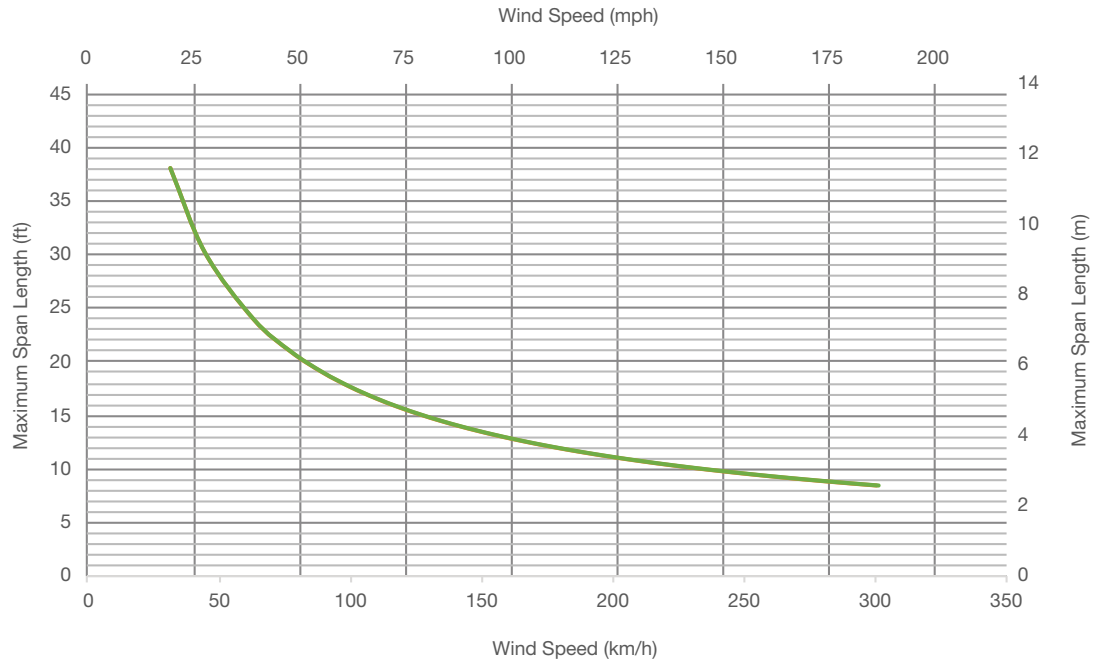
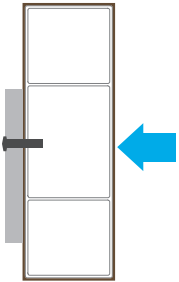

Span length for wind on narrow side

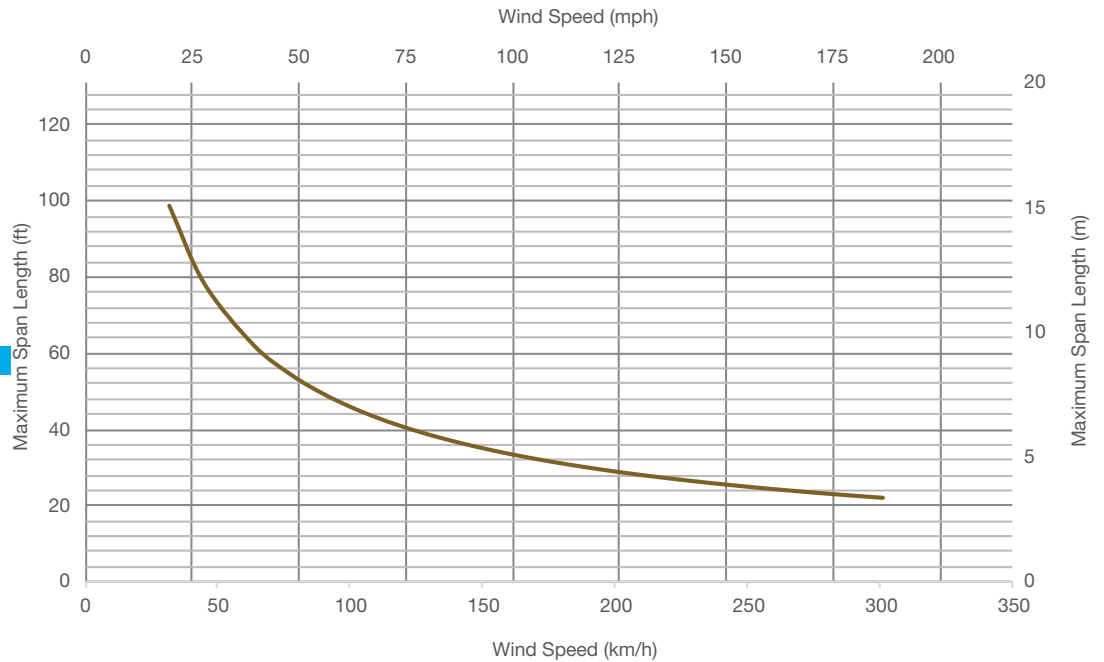
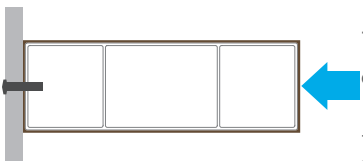

Soleo 6050



Dimensions	6" x 4" / 150 mm x 100 mm
Weight	2.62 lb/ft / 3.90 kg/ml
End Caps	No
Splices/Connectors	No

Span length for wind on wide side

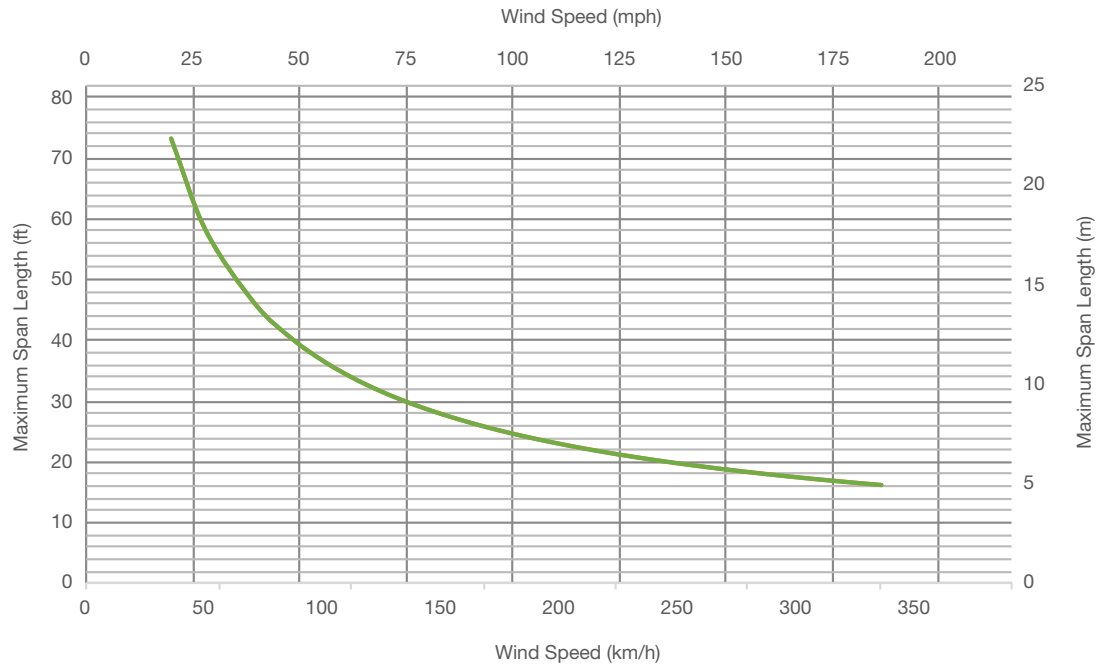
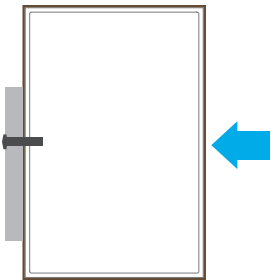

Span length for wind on narrow side

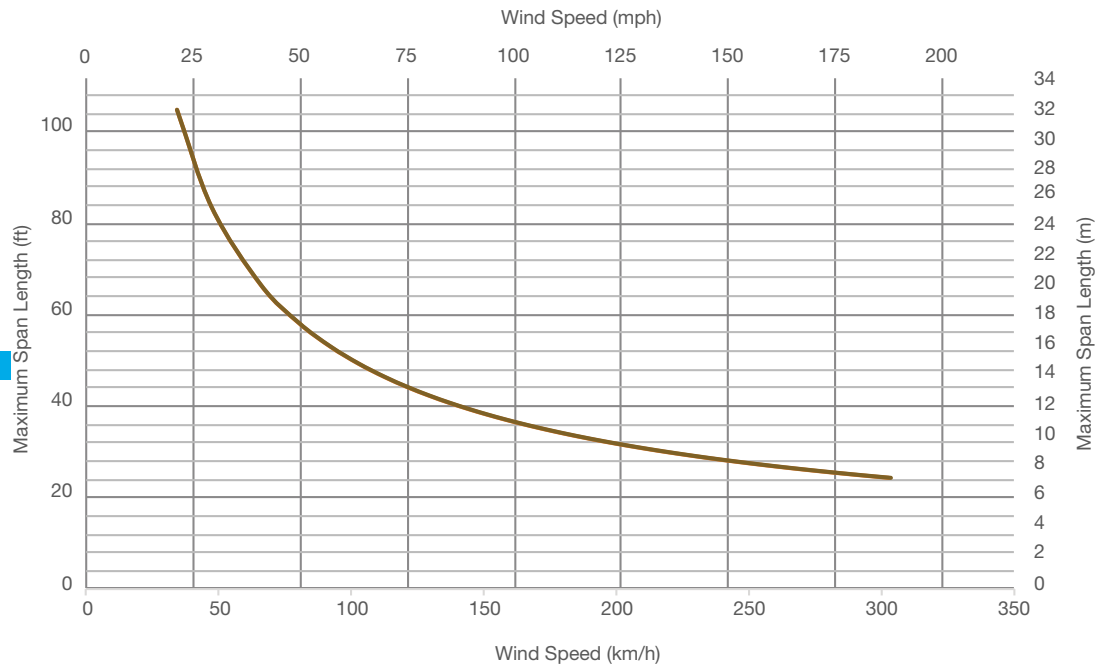

Soleo 6033



Dimensions	7 ⁷ / ₈ " x 1 ³ / ₈ " / 200 mm x 35 mm
Weight	2.22 lb/ft / 3.30 kg/ml
End Caps	Yes
Splices/Connectors	Yes

Span length for wind on wide side

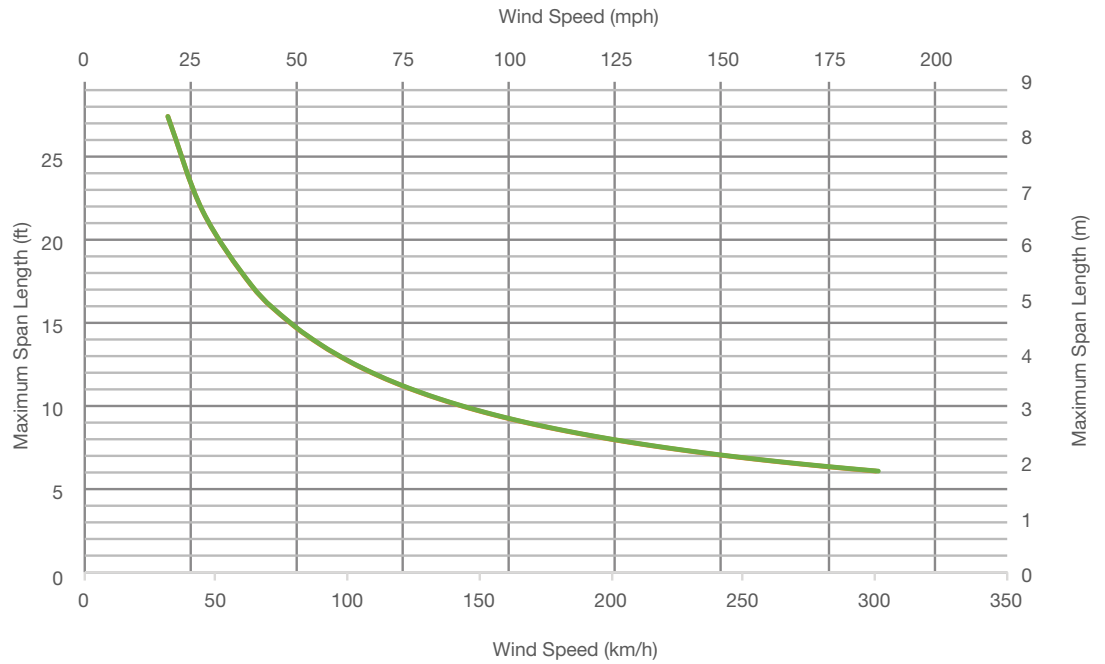
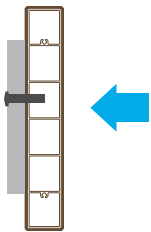

Span length for wind on narrow side

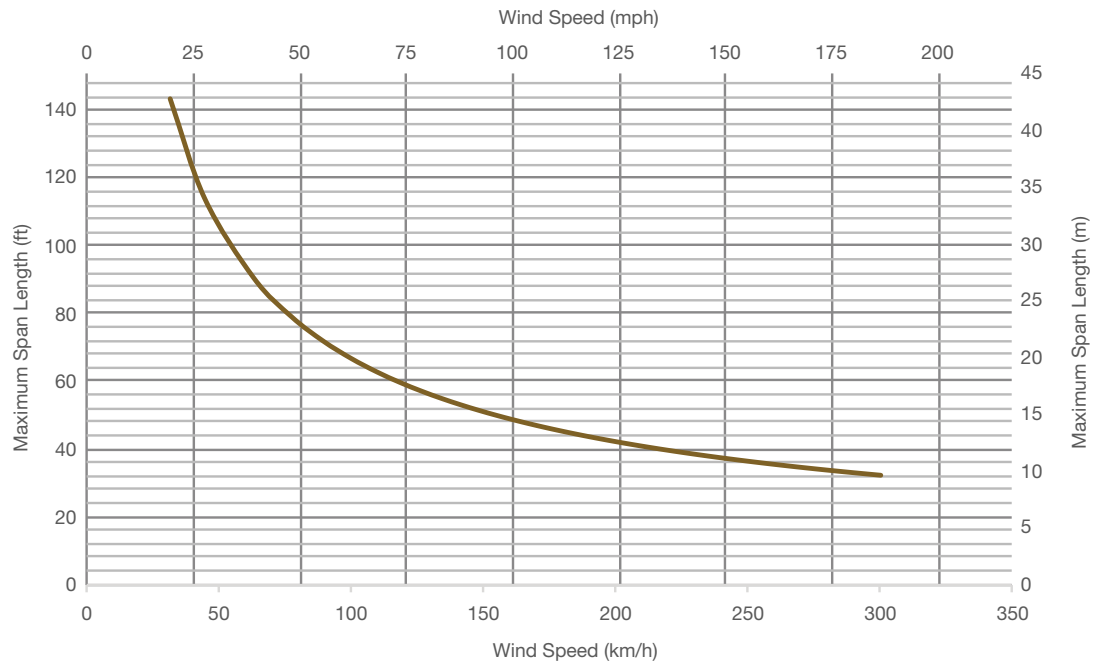
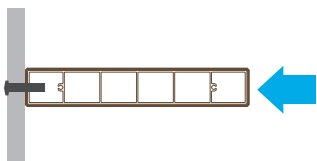

Planeo 4010



Dimensions	145 mm x 30 mm / 5 ³ / ₄ " x 1 ¹ / ₄ "
Weight	2.21 kg/ml / 1.49 lb/ft
End Caps	No
Splices/Connectors	No

Span length for wind on wide side

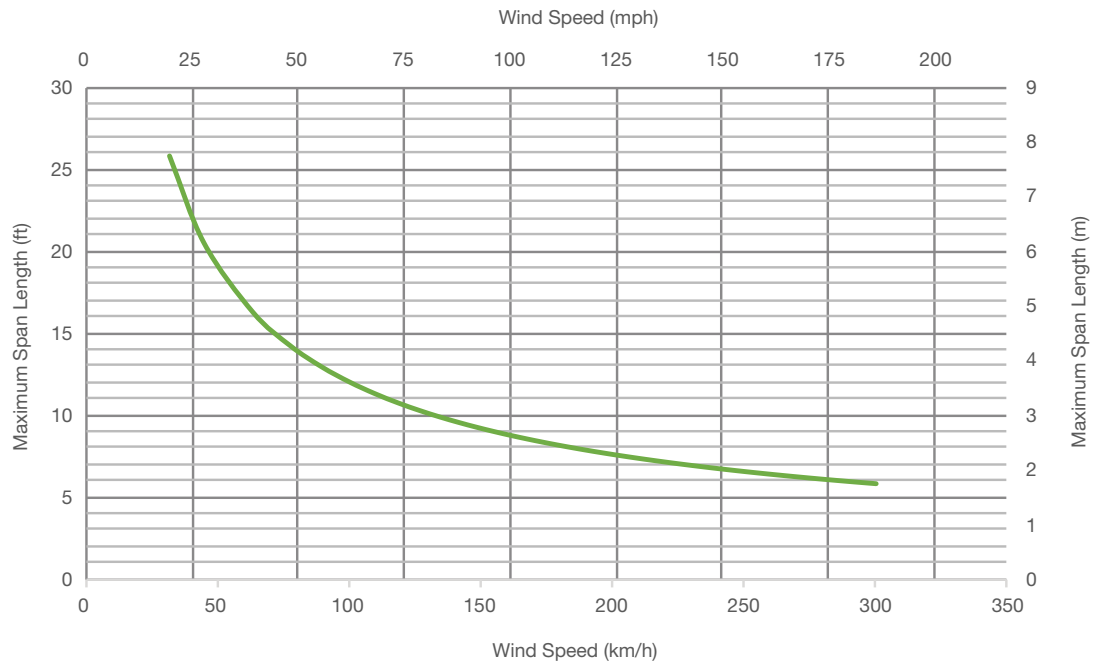
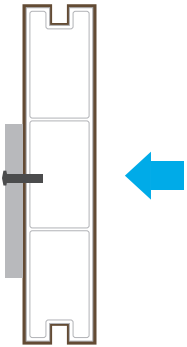

Span length for wind on narrow side

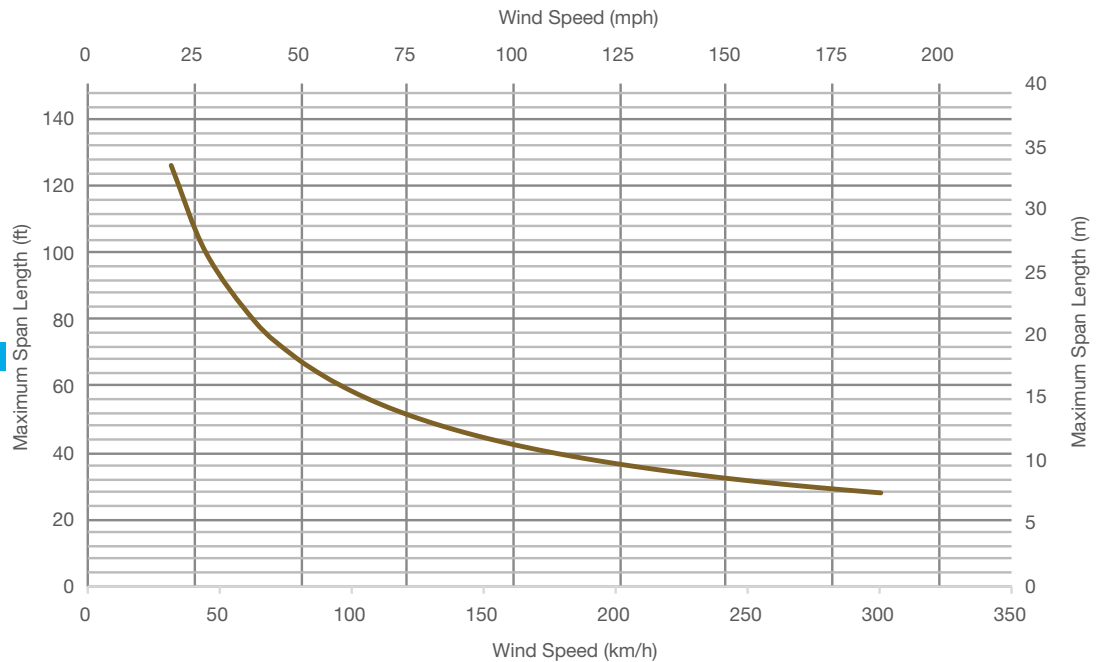
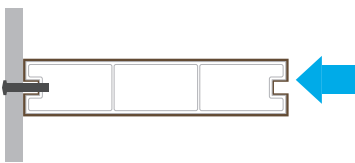

Planeo 4044

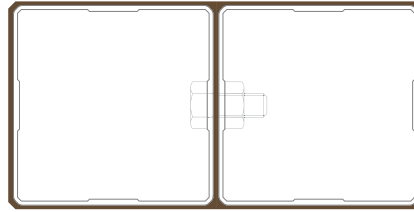

Dimensions	6 ⁷ / ₈ " x 3 ³ / ₈ " / 174 mm x 87 mm
Weight	3.04 lb/ft / 4.52 kg/ml
End Caps	No
Splices/Connectors	No

Planeo boards cannot be cut within the bolts at either board end. Refer to Architectural Elements Installation Guide for more details.

Span length for wind on wide side

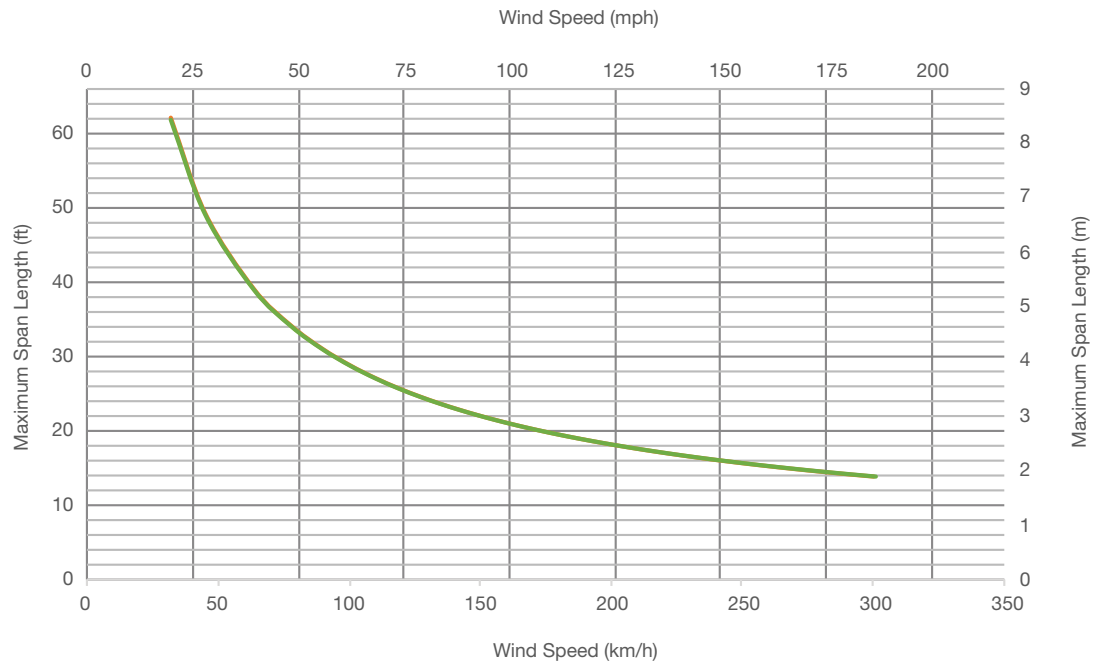
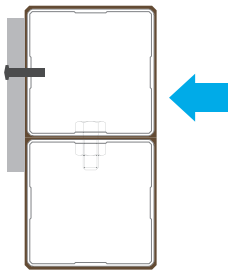

Span length for wind on narrow side

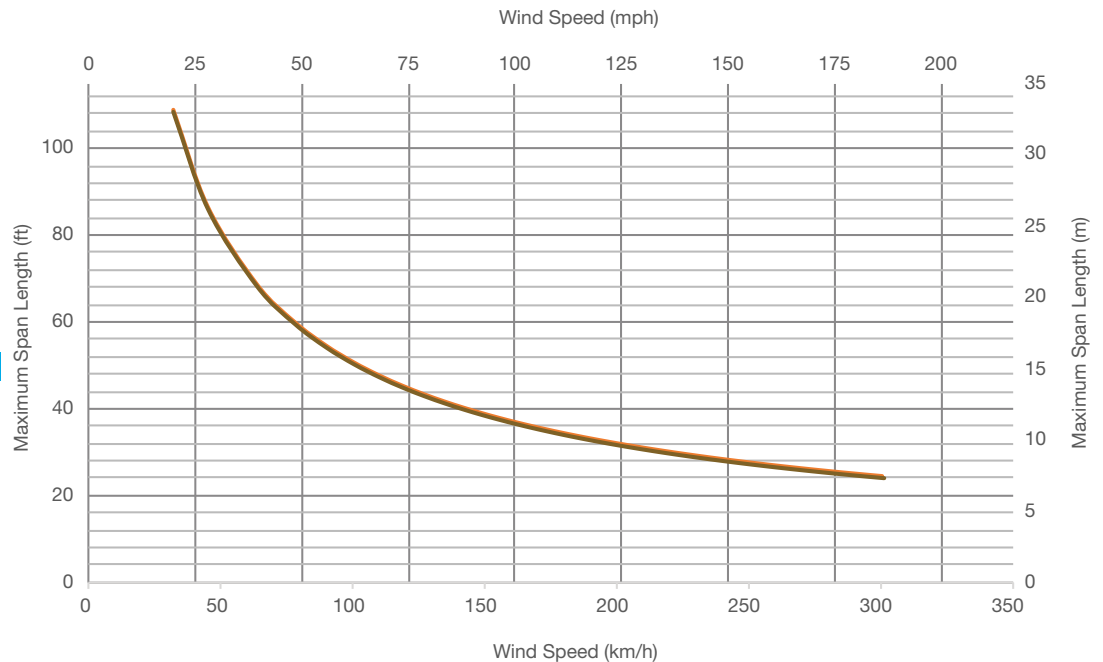
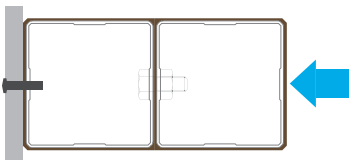

Planeo 4123

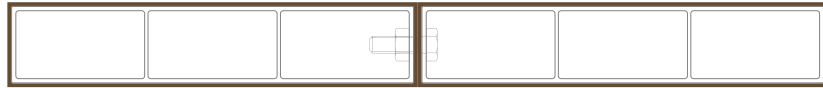

Dimensions	11 ³ / ₈ " x 1 ³ / ₈ " / 290 mm x 30 mm
Weight	2.51 lb/ft / 3.74 kg/ml
End Caps	No
Splices/Connectors	No

Planeo boards cannot be cut within the bolts at either board end. Refer to Architectural Elements Installation Guide for more details.

Span length for wind on wide side

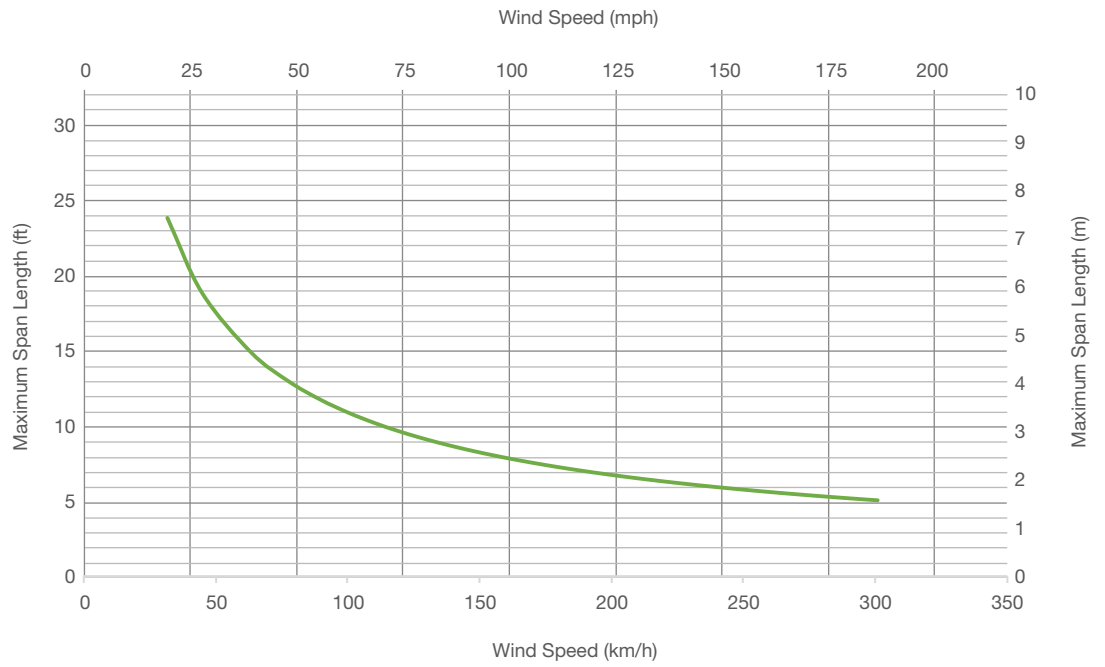
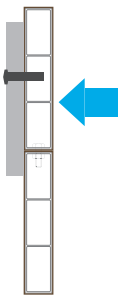

Span length for wind on narrow side

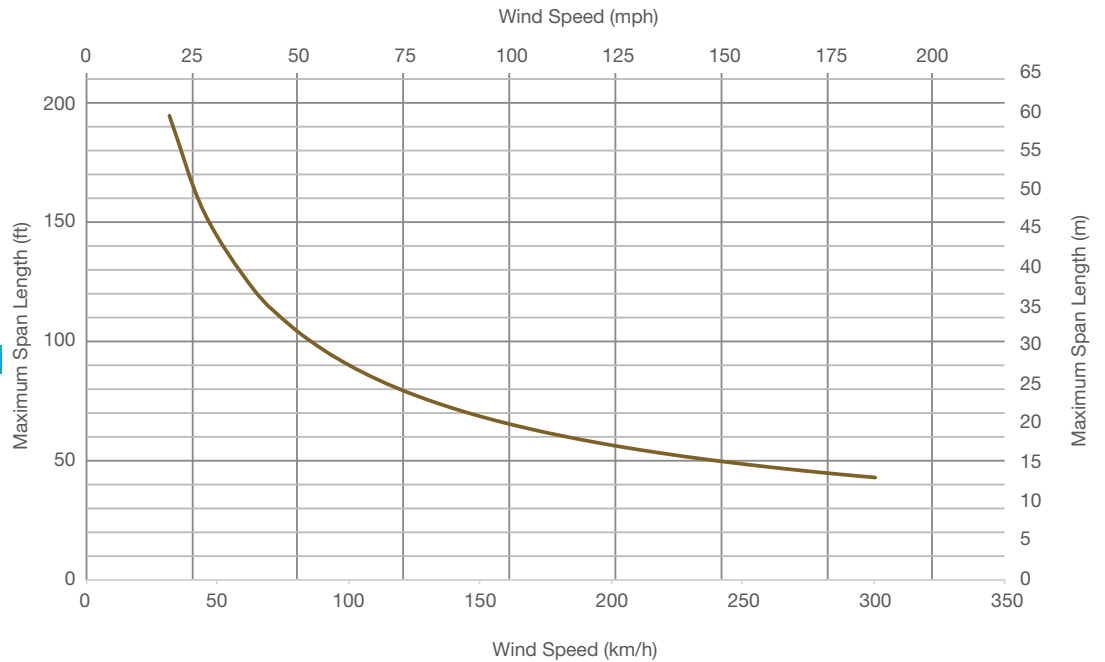
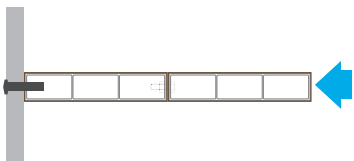

Planeo 4048

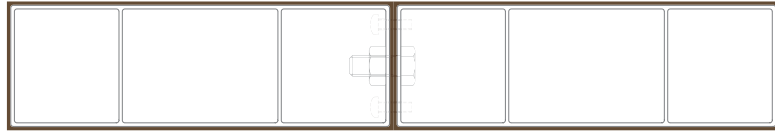

Dimensions	11 ³ / ₄ " x 2" / 300 mm x 50 mm
Weight	3.23 lb/ft / 4.80 kg/ml
End Caps	No
Splices/Connectors	No

Planeo boards cannot be cut within the bolts at either board end. Refer to Architectural Elements Installation Guide for more details.

Span length for wind on wide side

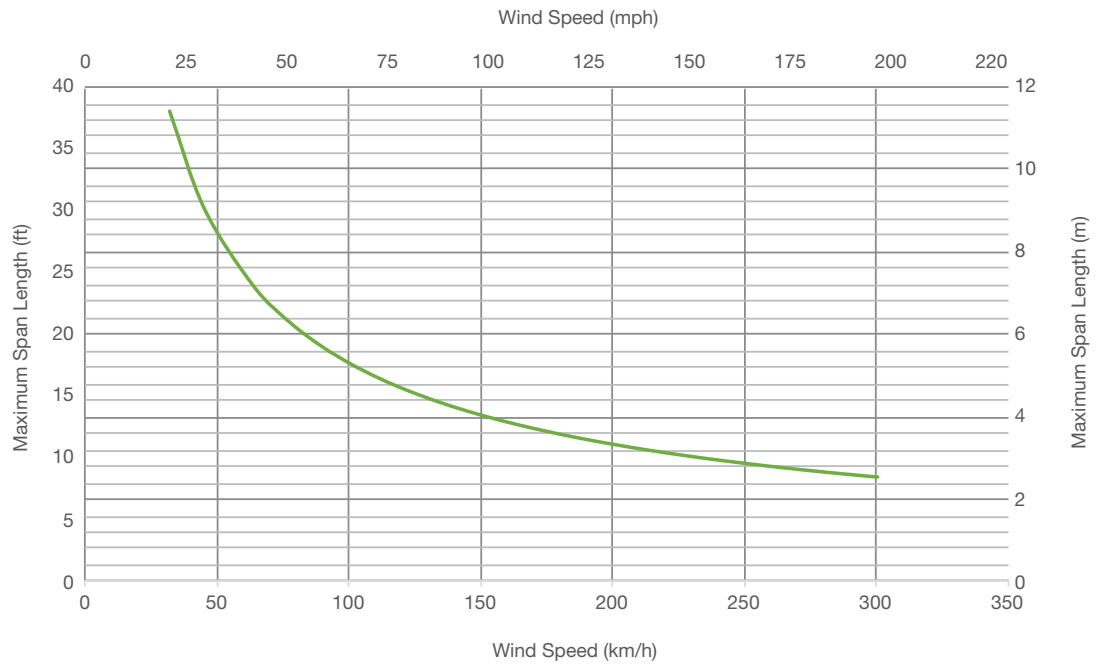
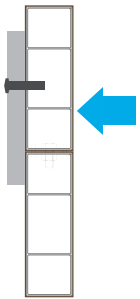

Span length for wind on narrow side

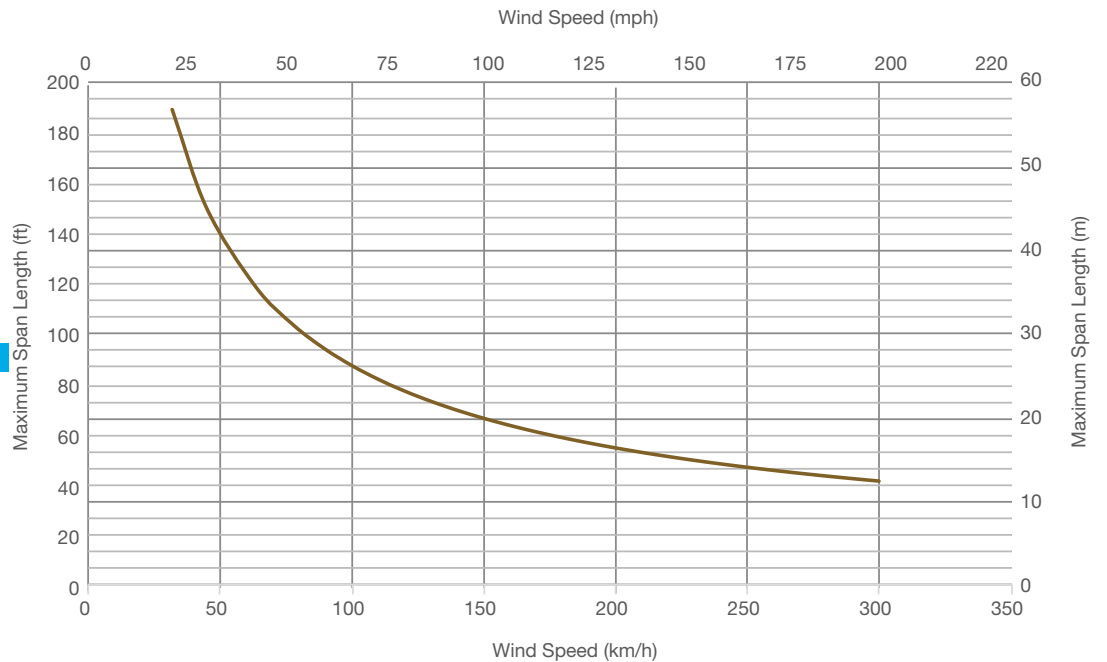
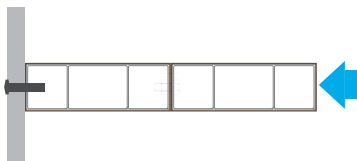

Planeo 4061

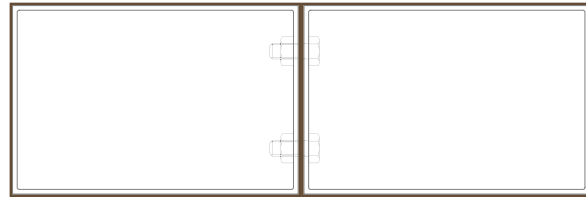

Dimensions	11 ³ / ₄ " x 4" / 300 mm x 100 mm
Weight	6.38 lb/ft / 9.50 kg/ml
End Caps	No
Splices/Connectors	No

Planeo boards cannot be cut within the bolts at either board end. Refer to Architectural Elements Installation Guide for more details.

Span length for wind on wide side

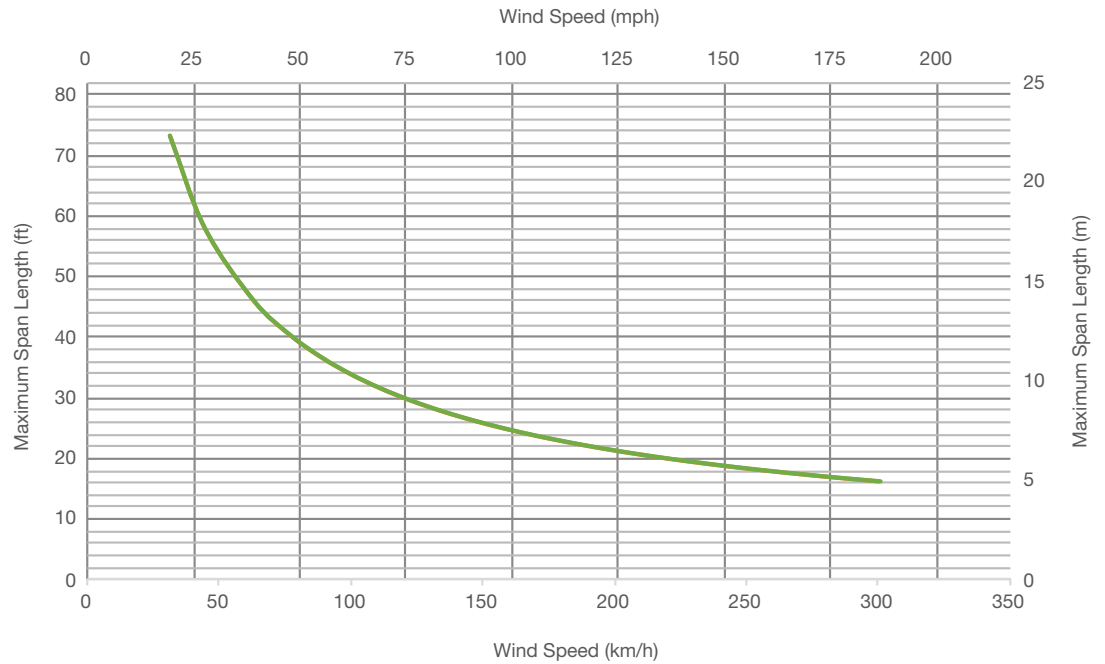
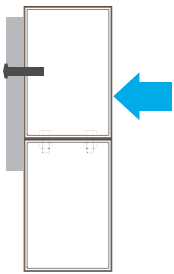

Span length for wind on narrow side

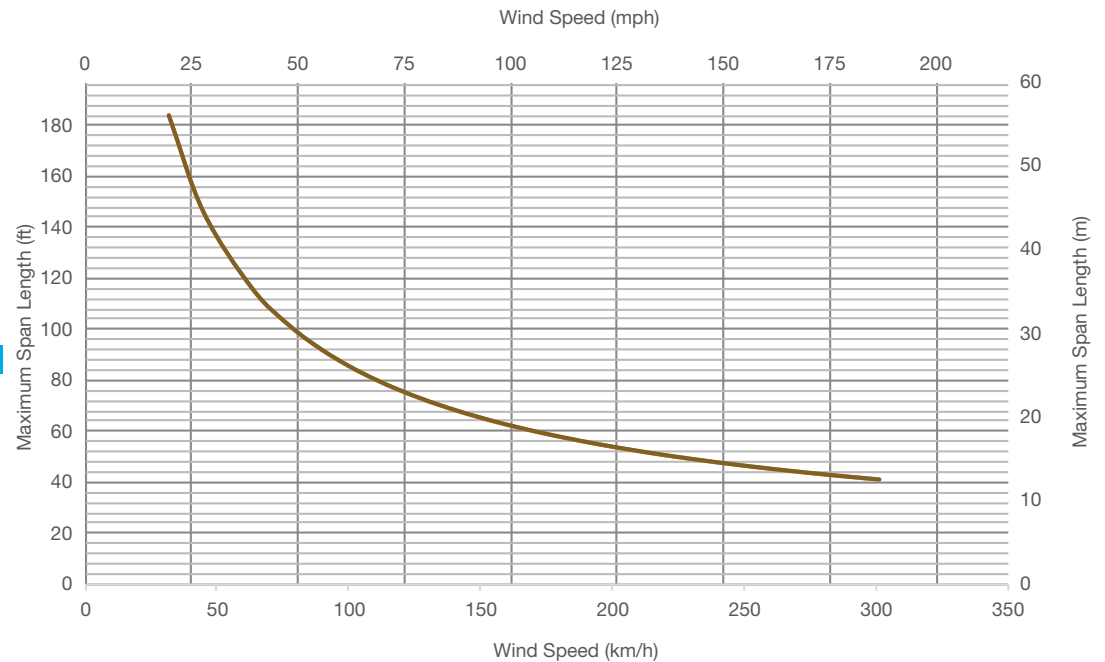
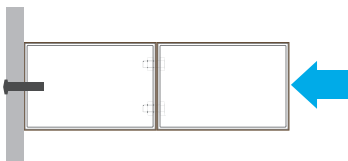

Planeo 4046

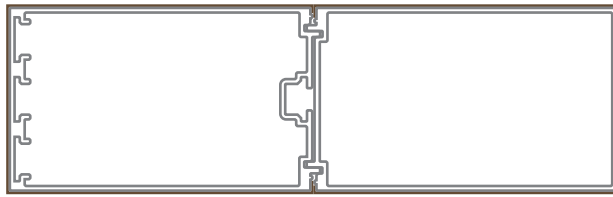

Dimensions	13 ³ / ₄ " x 4 ¹ / ₄ " / 350 mm x 110 mm
Weight	6.65 lb/ft / 9.90 kg/ml
End Caps	No
Splices/Connectors	No

Planeo boards cannot be cut within the bolts at either board end. Refer to Architectural Elements Installation Guide for more details.

Span length for wind on wide side

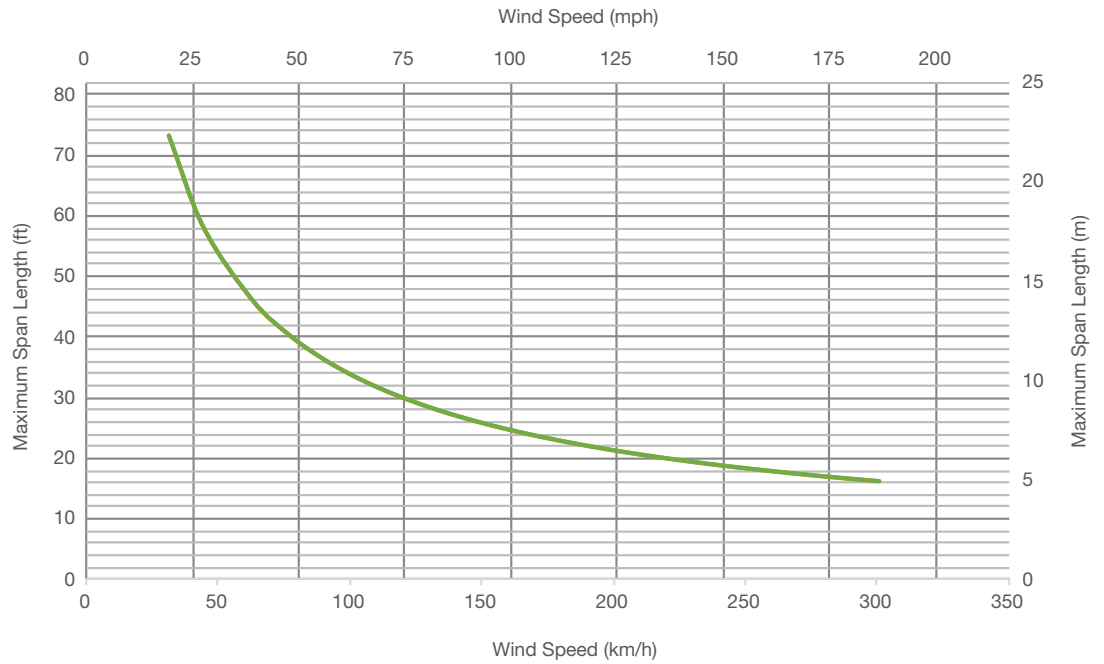
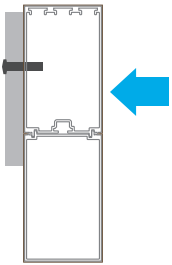

Span length for wind on narrow side

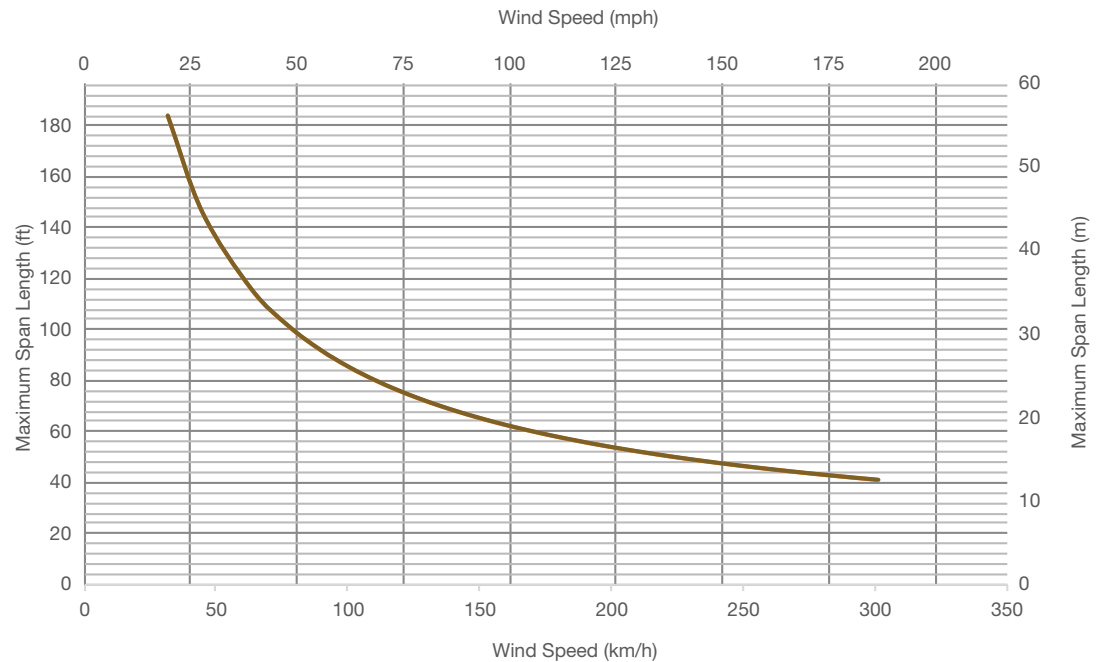
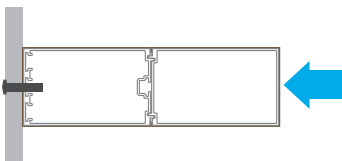

Planeo 4062

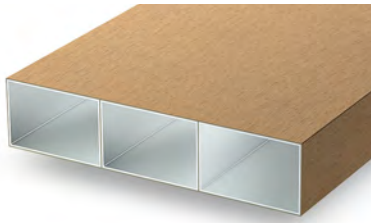

Dimensions	17 ³ / ₄ " x 4" / 450 mm x 100 mm
Weight	9.58 lb/ft / 14.25 kg/ml
End Caps	No
Splices/Connectors	No

Planeo boards cannot be cut within the bolts at either board end. Refer to Architectural Elements Installation Guide for more details.

Span length for wind on wide side

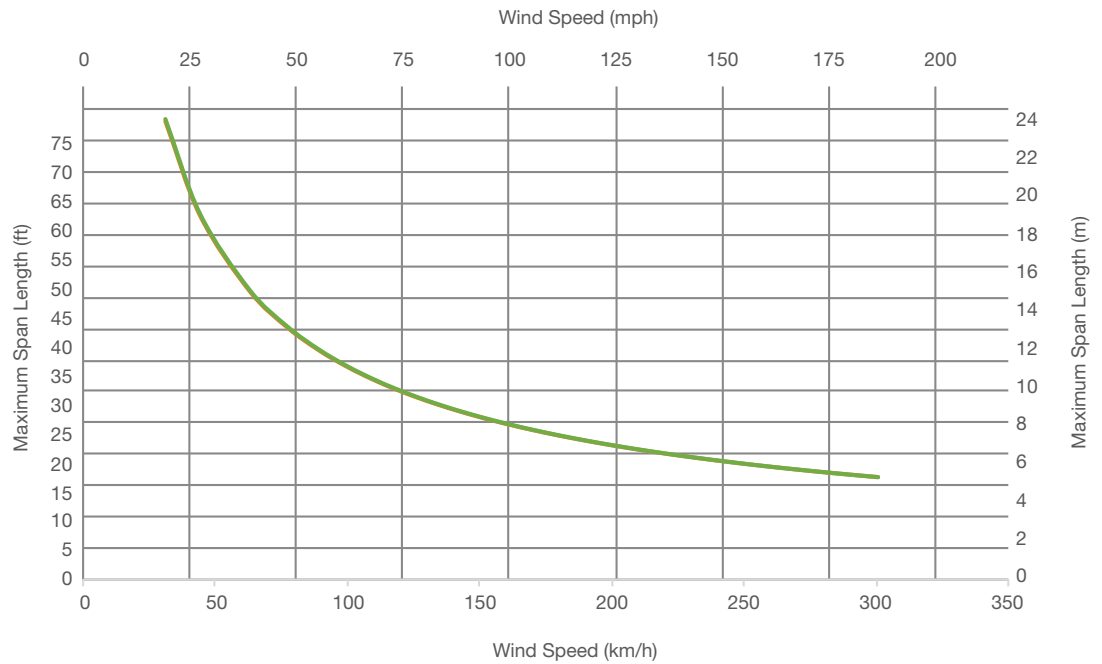
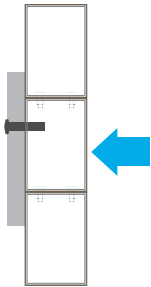

Span length for wind on narrow side

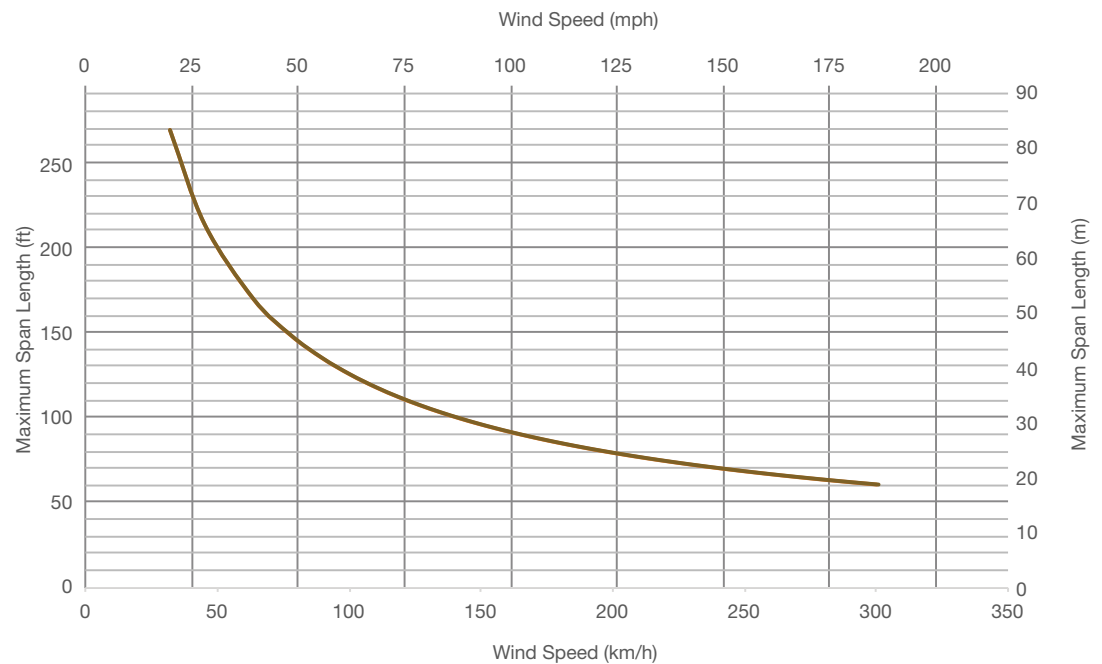
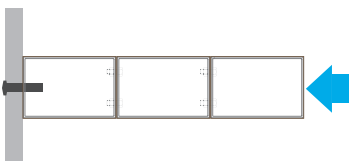

Diameo 2018

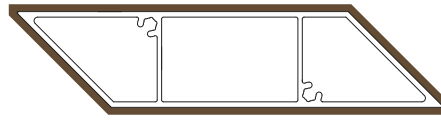

Dimensions	4 ³ / ₄ " x 1 ¹ / ₄ " / 120 mm x 30 mm
Weight	0.95 lb/ft / 1.42 kg/ml
End Caps	Yes
Splices/Connectors	Yes

Span length for wind on wide side

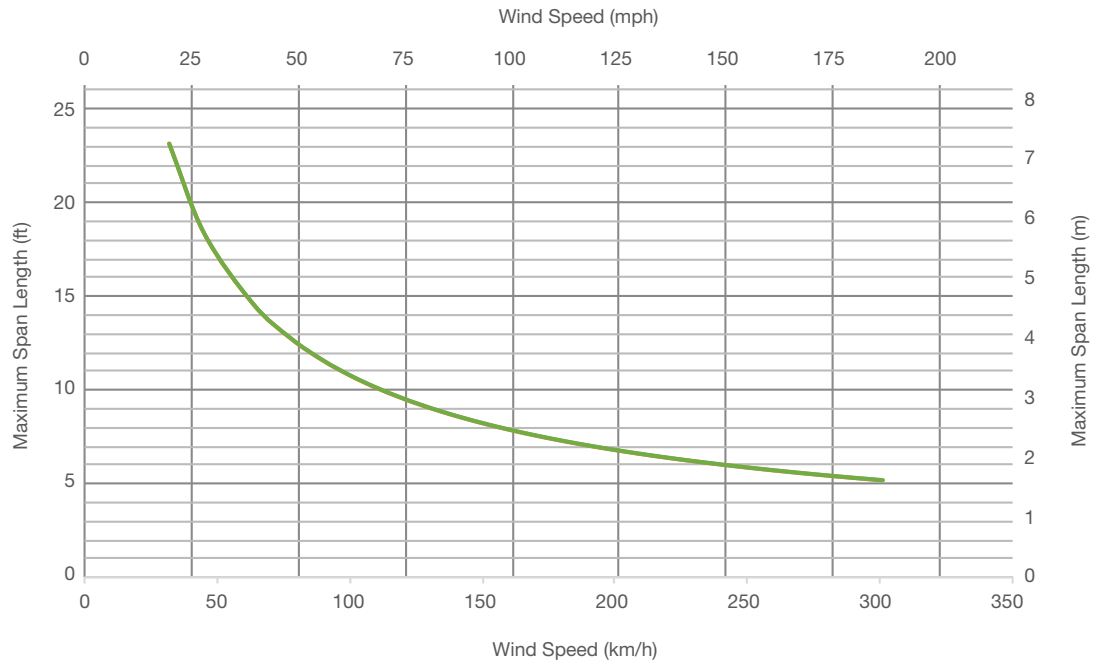
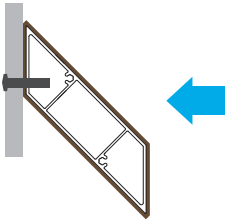

Span length for wind on narrow side

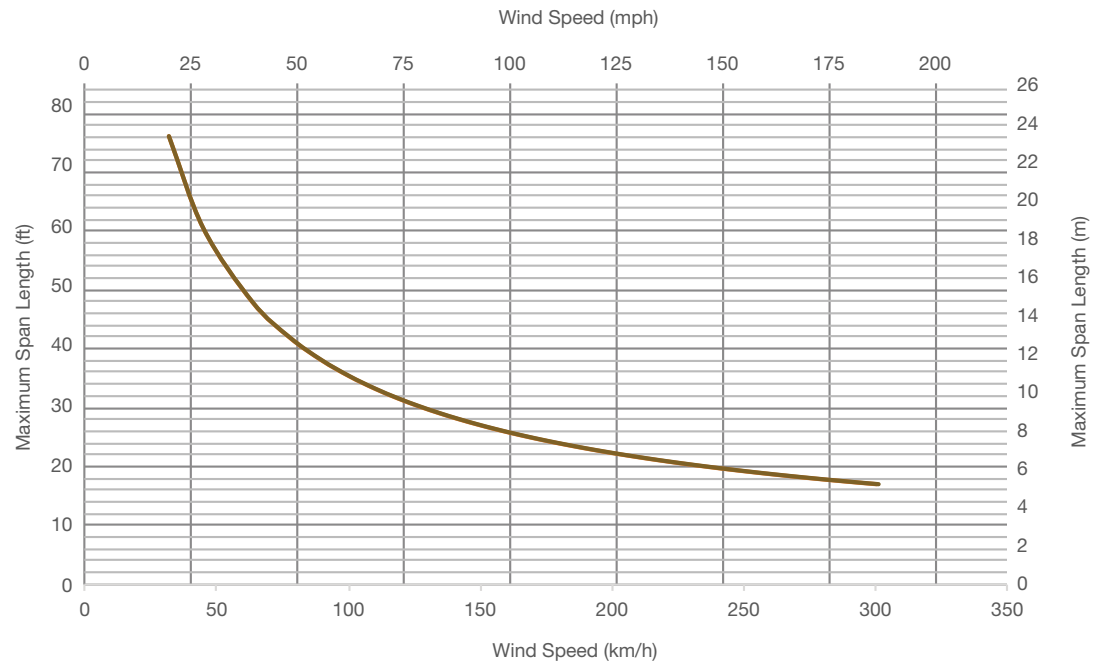
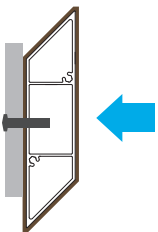

Diameo 2023

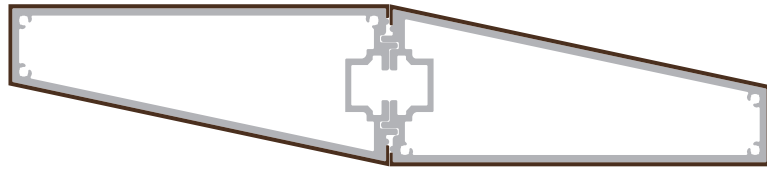
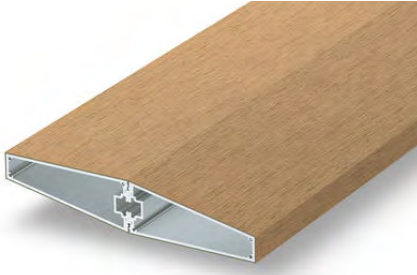

Dimensions	11 ³ / ₄ " x 2 ³ / ₈ " / 60 mm x 300 mm
Weight	4.99 lb/ft / 7.43 kg/ml
End Caps	No
Splices/Connectors	No

Span length for wind on wide side

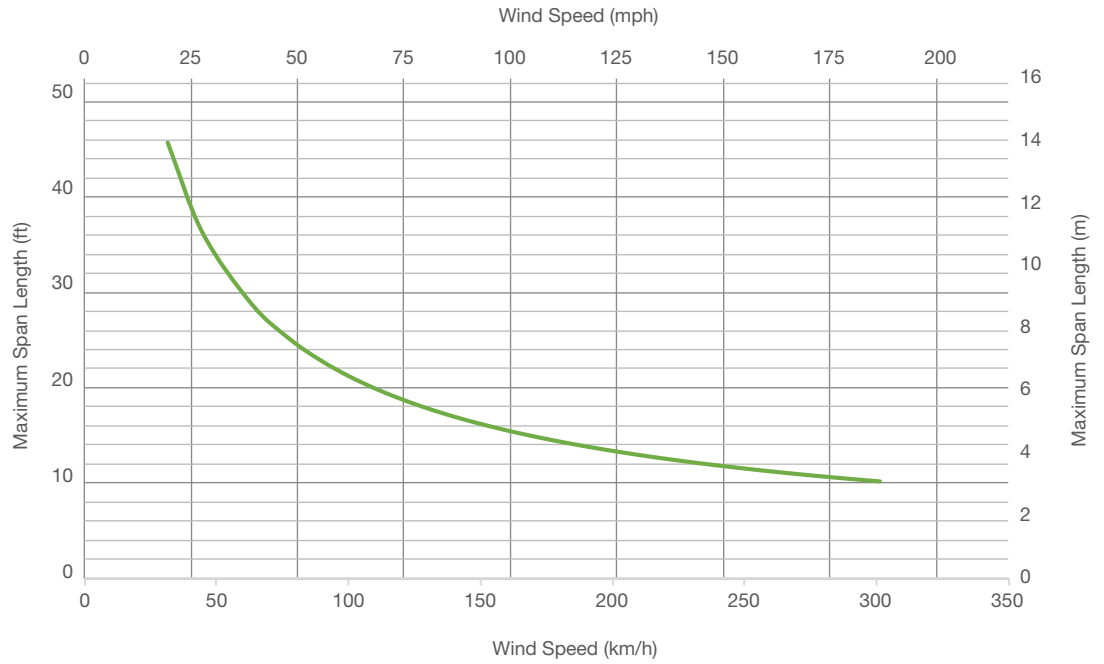
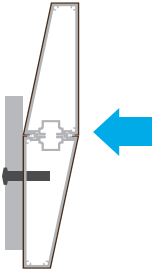

Span length for wind on narrow side

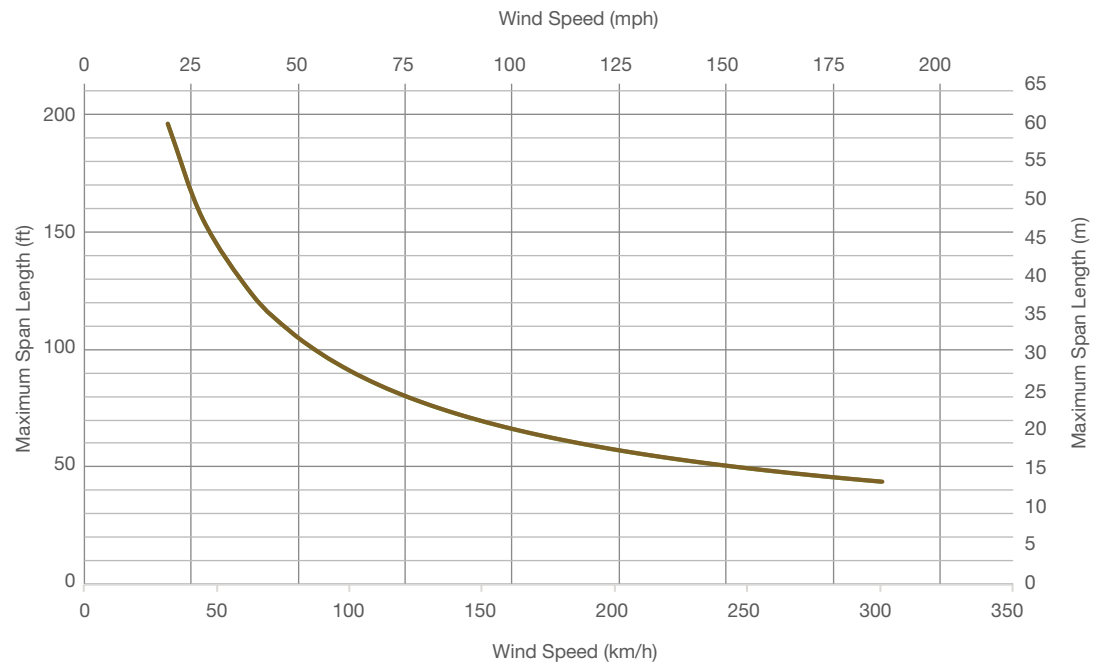
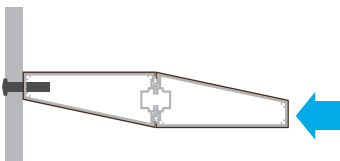

Careo 7010

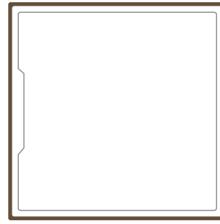

Dimensions	1 ³ / ₄ " x 1 ³ / ₄ " / 44 mm x 44 mm
Weight	0.50 lb/ft / 0.74 kg/ml
End Caps	No
Splices/Connectors	No

Span length for wind

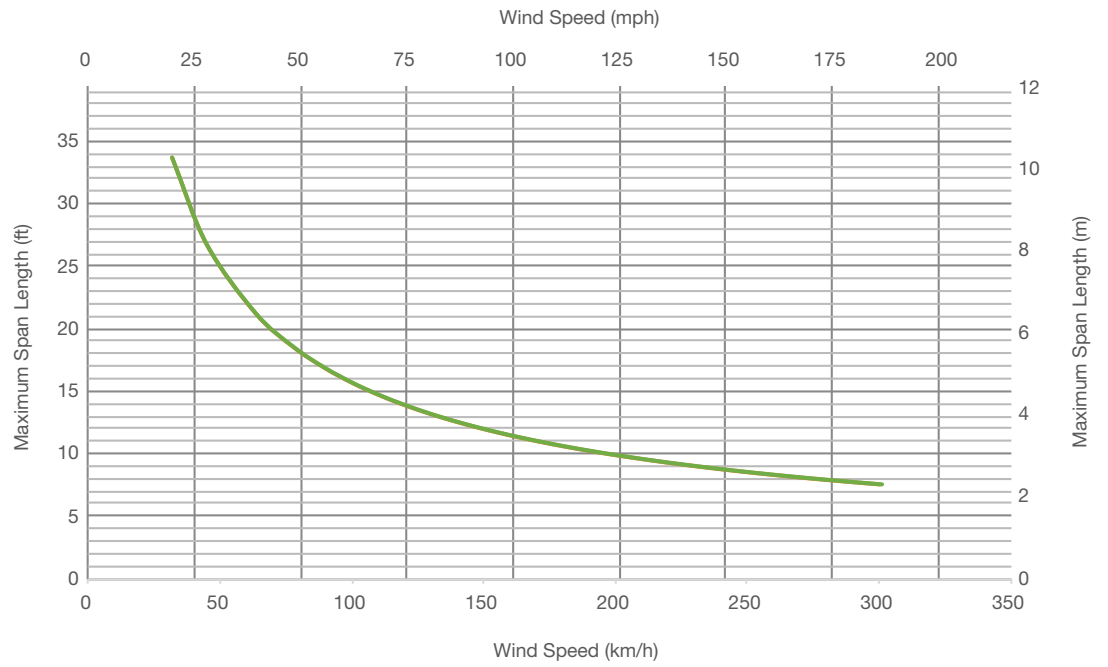
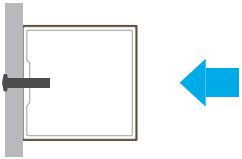

Careo 7031

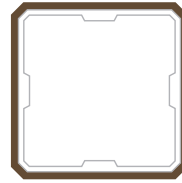

Dimensions	1 ³ / ₄ " x 1 ³ / ₄ " / 45 mm x 45 mm
Weight	0.55 lb/ft / 0.82 kg/ml
End Caps	No
Splices/Connectors	No

Span length for wind

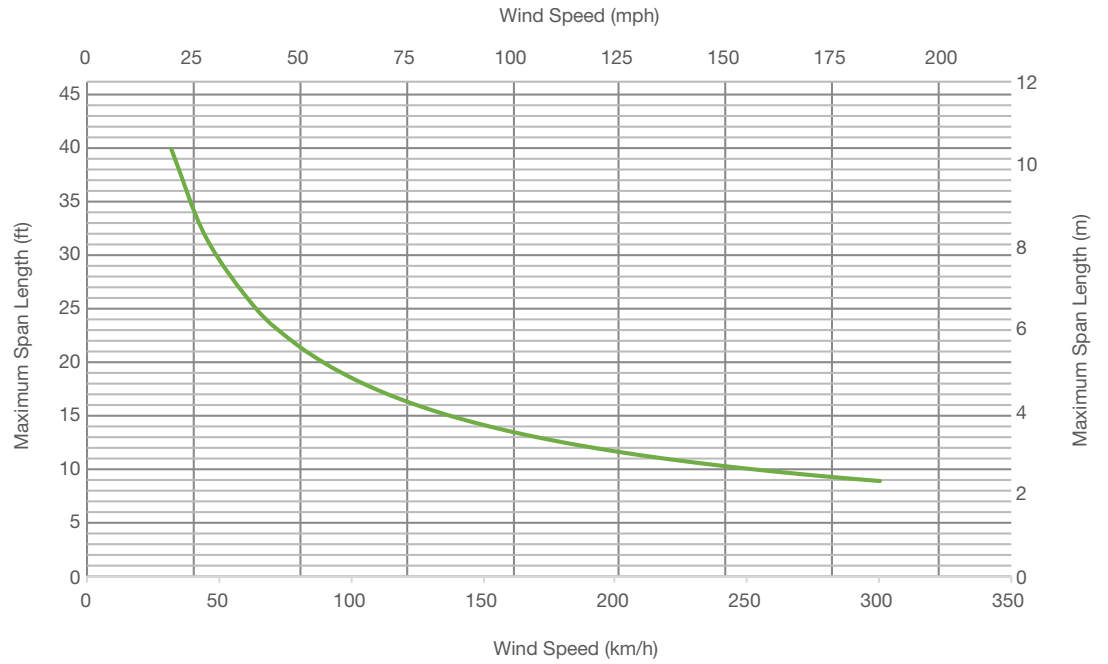
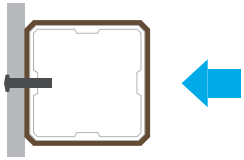

Careo 7011

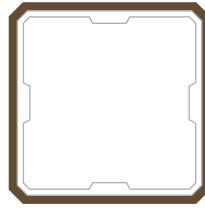

Dimensions	2 ¹ / ₈ " x 2 ¹ / ₈ " / 53 mm x 53 mm
Weight	0.90 lb/ft / 1.34 kg/ml
End Caps	No
Splices/Connectors	Yes

Span length for wind

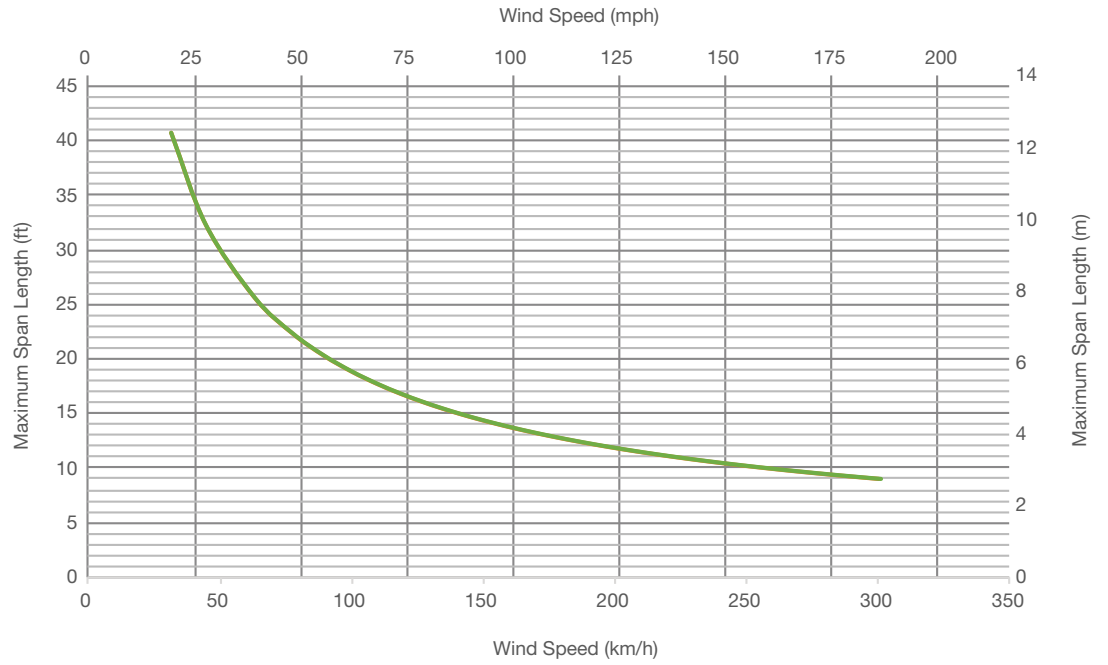
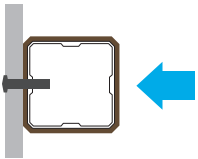

Careo 7035

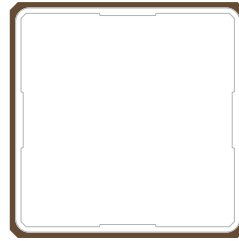

Dimensions	3 ³ / ₈ " x 3 ³ / ₈ " / 87 mm x 87 mm
Weight	1.53 lb/ft / 2.28 kg/ml
End Caps	No
Splices/Connectors	No

Span length for wind

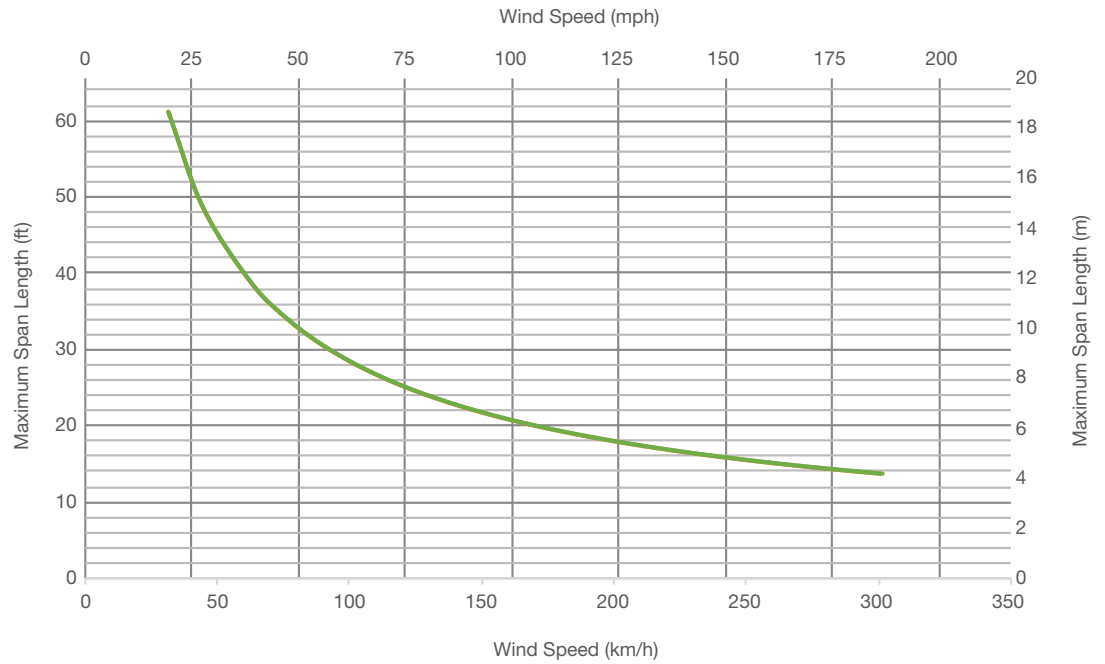
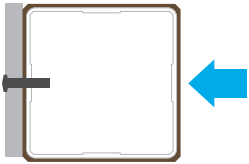

Careo 7014



Dimensions	3 1/2" x 3 1/2" / 88 mm x 88 mm
Weight	1.88 lb/ft / 2.80 kg/ml
End Caps	Yes
Splices/Connectors	No

Span length for wind

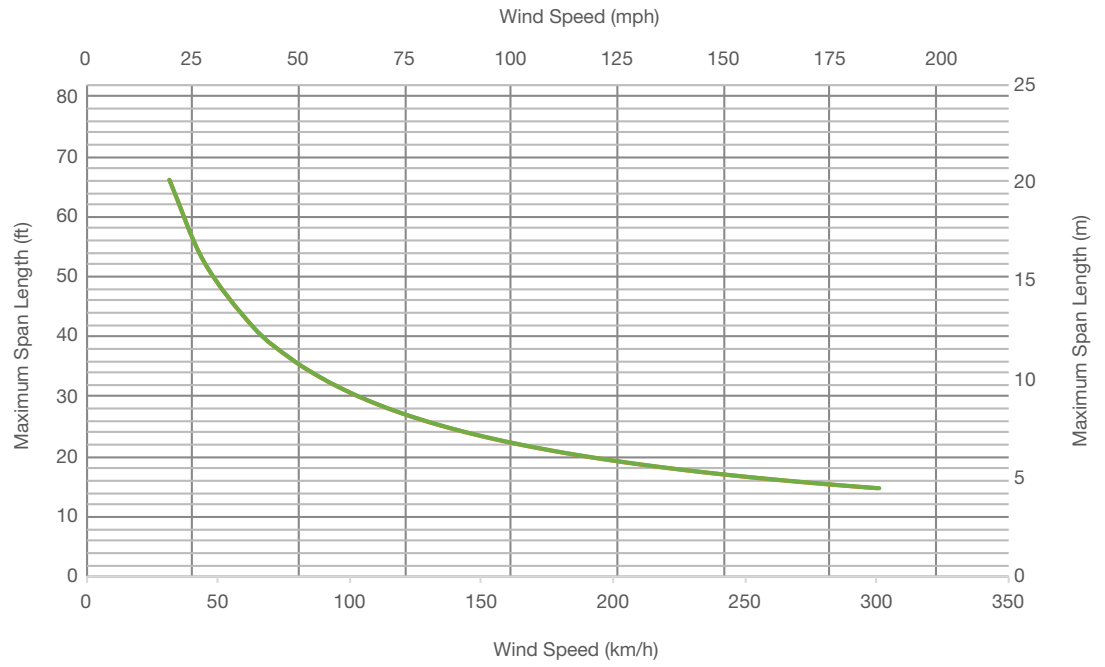
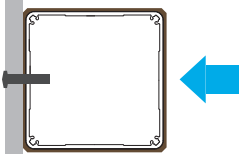

Careo 7016



Dimensions	4 ³ / ₄ " x 4 ³ / ₄ " / 120 mm x 120 mm
Weight	2.69 lb/ft / 4.00 kg/ml
End Caps	No
Splices/Connectors	No

Span length for wind

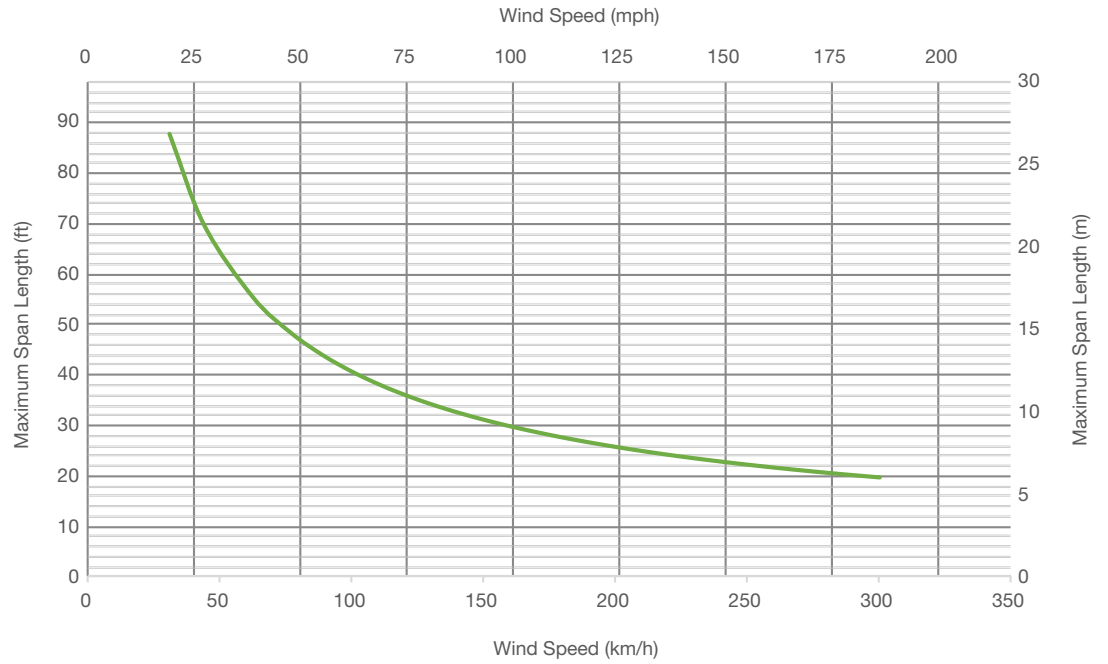
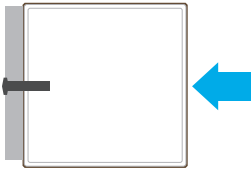

Vertigo 5010



Dimensions	7 ¹ / ₄ " x 1 ¹ / ₂ " / 184 mm x 13 mm
Weight	0.80 lb/ft / 1.19 kg/ml
End Caps	No
Splices/Connectors	No

Span length for wind

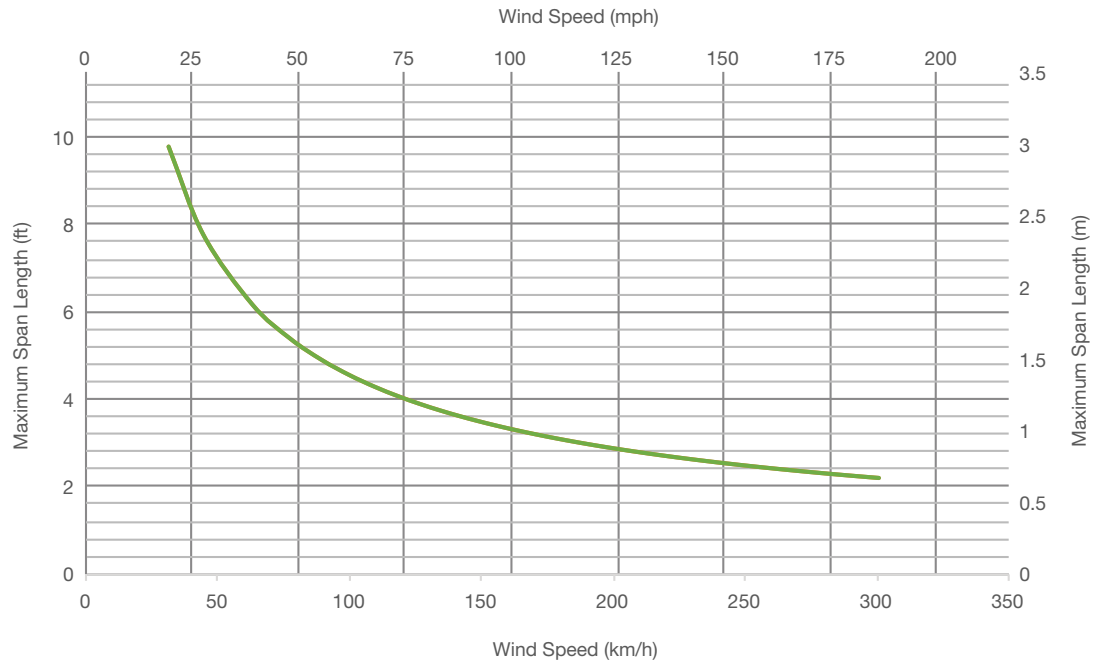
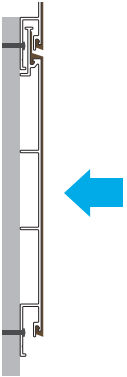

Architectural Elements



SOLEO - 18 PROFILES



PLANEO - 7 PROFILES



DIAMEO - 2 PROFILE



CAREO - 6 PROFILES

Cladding/Soffit



VERTIGO - 1 PROFILE

Commercial Decking

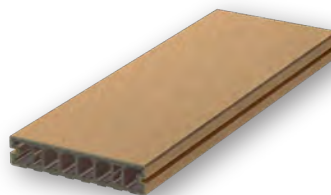

QUALITA - 2 PROFILES

To learn more about the advantages of Geolam[®], our complete product line, or for any other information, please visit our website or contact us at any time.

usa.geolam.com

Toll free: 1-877-627-3530 • info@geolaminc.com

Geolam[®]
Architectural Eco-Technology

10-YEAR LIMITED WARRANTY

Extent of coverage:

This warranty is given to the original Purchaser of GEOLAM® wood plastic composite decking and/or cladding boards and/or hybrid aluminum/wpc boards. This warranty does not extend to fasteners that are not supplied by the boards' manufacturer.

Geolam, Inc. guarantees the Purchaser that, for a period of ten (10) years (the term) from the date of the original purchase, under normal use and service conditions, the GEOLAM® decking and/or cladding boards and/or hybrid aluminum/wpc boards be free from material defects in workmanship and materials, and will not split, splinter, rot or suffer structural damage from termites or fungal decay.

If such a defect appears during the term, Geolam, Inc. will, at its option, supply replacement product (but not the labour cost, freight, taxes or other expenses associated with de-installation and reinstallation) or refund the purchase in an amount not to exceed Manufacturer's cost of material.

How To File A Warranty Claim:

Purchaser must notify Geolam, Inc. in writing within thirty (30) days after the appearance of the defect, but no later than the end of the Term.

Purchaser shall send a brief written explanation of the defect, along with dated proof of purchase to Geolam, Inc., 9 Shorncliffe Avenue, Toronto, ON, M4V 1S9. Manufacturer reserves the right to request additional information, including, but not limited to, photos, and to conduct a field inspection.

Exclusion of limited warranty:

This limited Warranty does not cover product failure, product malfunction or any damages resulting from:

- (a) improper installation of GEOLAM® products and/or failure to comply with Geolam, Inc.'s installation instructions
- (b) beyond normal use, or in an application not recommended by Geolam, Inc.'s installation instructions and local building codes;
- (c) movement, distortion, collapse or settling of the ground or the supporting structure on which GEOLAM® products are installed;
- (d) any act of God (such as flooding, hurricane, earthquake, lightning, etc.), environmental condition (such as air pollution), or staining from foreign substances (such as dirt, grease, oil, etc.);
- (e) variations or changes in color of GEOLAM® products;
- (f) normal weathering due to exposure to sunlight, moisture, and atmosphere, and accumulation of dirt or stains;
- (g) damages of any kind caused by animals, domestic or otherwise;
- (h) improper handling, storage, abuse or neglect of GEOLAM® products by Purchaser, or third parties;
- (i) any fasteners not supplied by Geolam, Inc.; and

Failure to strictly adhere to Manufacturer's written instruction manual for the installation, use or maintenance of GEOLAM® will render this Limited Warranty null and void.

Limitations of remedies and exclusion of consequential and incidental damages

To the extent permitted by law, Geolam, Inc.'s liabilities are limited solely and exclusively to the obligations specifically specified herein and under no circumstances will Geolam, Inc. be liable or obligated for any incidental, consequential, indirect, special, punitive or any other damages of any kind whatsoever.

This writing is understood and intended to be the final expression of the parties' agreement and is **a complete and exclusive statement** of the terms and conditions with respect thereto, superseding all prior agreements or representations, oral or written, and all other communication between the parties relating to the subject matter of this agreement. No agent, employee or any other party is authorized to make any warranty on behalf of Geolam, Inc. in addition to that made in this agreement.

This warranty is effective for purchases made on or after May 1, 2011.