

# Soleo 6040

**Geolam**<sup>®</sup>  
Architectural Eco-Technology

## Hybrid Aluminum/WPC Architectural Elements

Datasheet

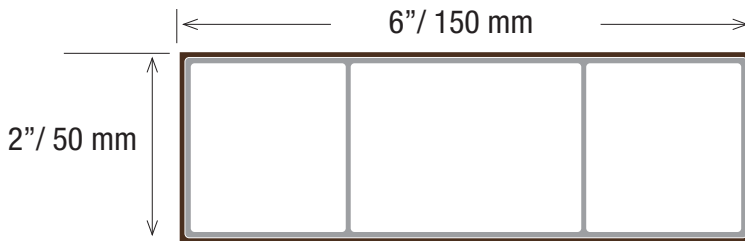
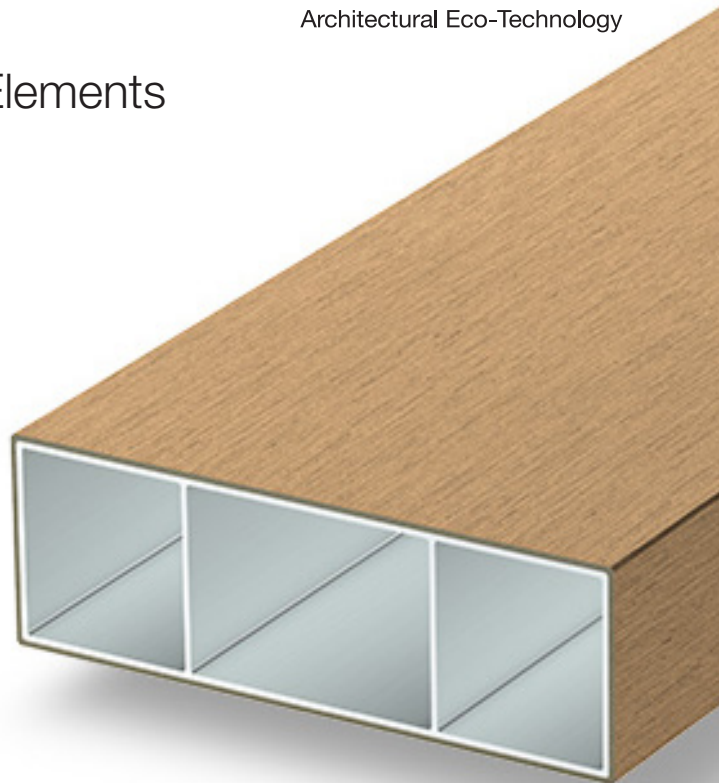

*Technical information may change without warning.  
Please ensure you that you reference our latest as shown on our website at [www.usa.geolam.com](http://www.usa.geolam.com)*

**Thickness:** 2 in | 50 mm  
**Width:** 6 in | 150 mm  
**Section tolerances in mm:** + 0.5 / - 2.0

**Fire rating:**  
On request before order

**Surfaces finish:** Sanded

**Profiles fastening and installation:**  
Check our website [www.usa.geolam.com](http://www.usa.geolam.com)

**Standard length:** 9 ft 10 in | 3.0 m

**Or order custom lengths from:**  
7 ft to 19 ft 8 in | 2.15 m to 6 m

**Weight:** 1.61 lb/ft | 2.40 kg/m

**Secondary moment I<sub>x</sub> (cm<sup>4</sup>):** 26.88

**Secondary moment I<sub>y</sub> (cm<sup>4</sup>):** 156.14

**Section modulus Z<sub>+x</sub> (cm<sup>3</sup>):** 11.44

**Section modulus Z<sub>-x</sub> (cm<sup>3</sup>):** 11.44

**Section modulus Z<sub>+y</sub> (cm<sup>3</sup>):** 21.24

**Section modulus Z<sub>-y</sub> (cm<sup>3</sup>):** 21.24

**Core in anodized aluminum alloy:**  
A6063S-T5 Serie 6000

**Coefficient of Thermal Expansion (20-100°C):**  
23.4 μm/m/°C

**Modulus of Elasticity:** 68.9 GPa

**Max Tensile Strength:** 186 Mpa

**Carbon Footprint:**  
WPC : 1.54 kg CO<sub>2</sub> /Kg  
Profile : 9.005 kg CO<sub>2</sub> /Kg

*Sanding finish and/or shading may vary between runs*

**Standard Colors** - Minimum 1,600 lineal ft. for all colors.



Teak



Moleskin



Rosewood



Ebony

**Non-Standard Colors** - 90 day lead time - Minimum order 5,000 lineal ft.



Blackwood



Bilinga

**Custom Colors Available** - Minimum order 6,000 lineal ft.

[www.usa.geolam.com](http://www.usa.geolam.com)  
Toll free: 1-877-627-3530  
[info@geolaminc.com](mailto:info@geolaminc.com)

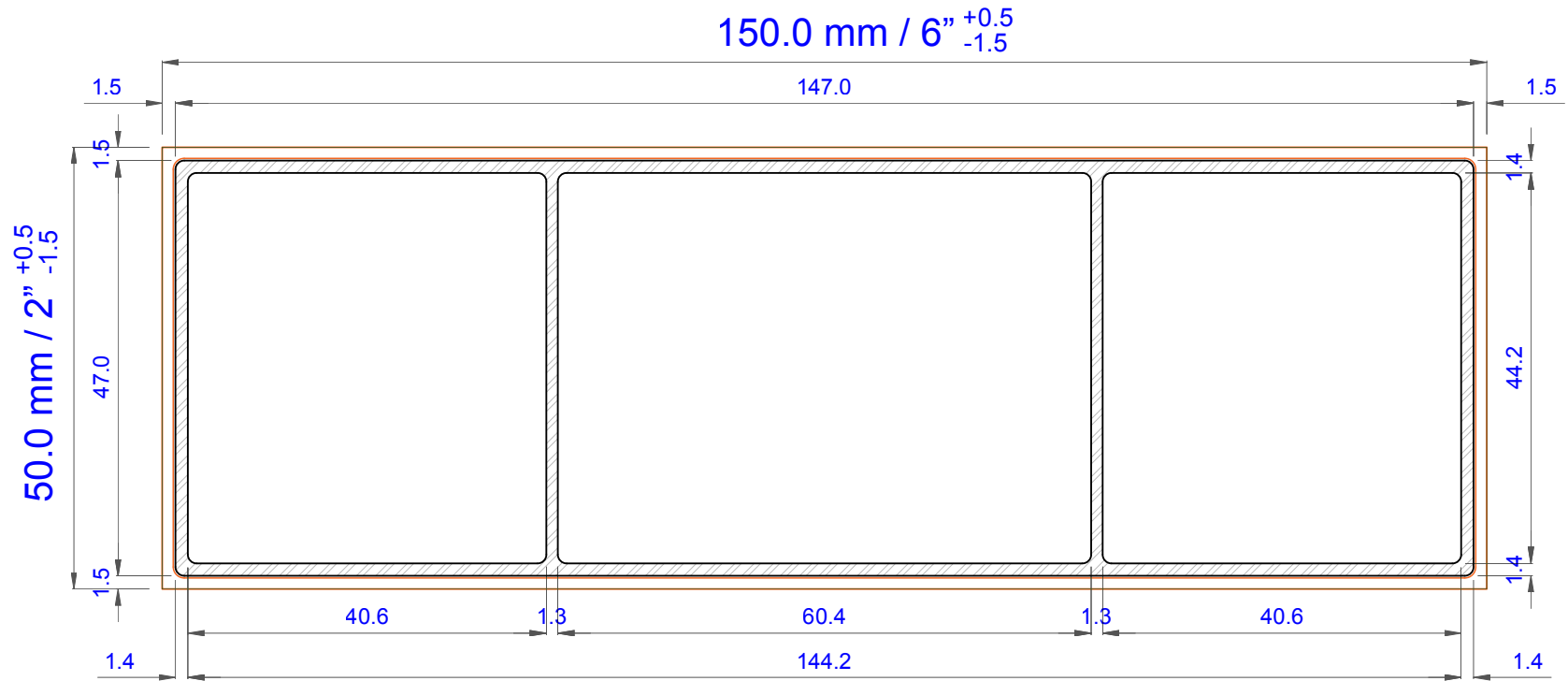

<b>Technical specifications, dimensions in mm</b>		Cross section coefficient Z+x (cm <sup>3</sup> )	11.44	<b>Wood hybrid system WHS</b>	Type 1.0
Weight (kg/ml)	2.4	Cross section coefficient Z-x (cm <sup>3</sup> )	11.44	<b>Soleo 6040</b>	
Cross section, secondary moment Ix (cm <sup>4</sup> )	26.88	Cross section coefficient Z+y (cm <sup>3</sup> )	21.24		
Cross section, secondary moment Iy (cm <sup>4</sup> )	156.14	Cross section coefficient Z-y (cm <sup>3</sup> )	21.24		
				<b>Geolam</b> www.geolaminc.com	