

Soleo 6036

Geolam[®]
Architectural Eco-Technology

Hybrid Aluminum/WPC Architectural Elements

Datasheet

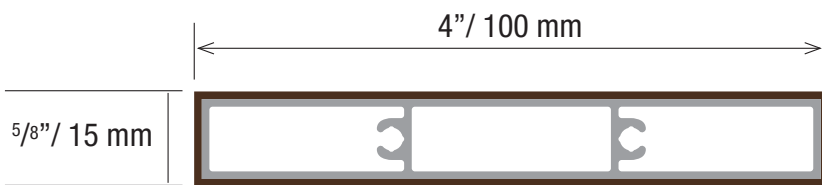

*Technical information may change without warning.
Please ensure you that you reference our latest as shown on our website at www.usa.geolam.com*

Thickness: 5/8 in | 15 mm
Width: 4 in | 100 mm
Section tolerances in mm: + 0.5 / - 2.0

Fire rating:
On request before order

Surfaces finish: Sanded

Profiles fastening and installation:
Check our website www.usa.geolam.com

Standard length: 9 ft 10 in | 3.0 m

Or order custom lengths from:
7 ft to 19 ft 8 in | 2.15 m to 6 m

Weight: 0.67 lb/ft | 1.00 kg/m

Secondary moment I_x (cm⁴): 0.82

Secondary moment I_y (cm⁴): 26.05

Section modulus Z_{+x} (cm³): 1.31

Section modulus Z_{-x} (cm³): 1.31

Section modulus Z_{+y} (cm³): 5.34

Section modulus Z_{-y} (cm³): 5.34

Core in anodized aluminum alloy:
A6063S-T5 Serie 6000

Coefficient of Thermal Expansion (20-100°C):
23.4 μm/m/°C

Modulus of Elasticity: 68.9 GPa

Max Tensile Strength: 186 Mpa

Carbon Footprint:
WPC : 1.54 kg CO₂ /Kg
Profile : 9.005 kg CO₂ /Kg

Sanding finish and/or shading may vary between runs

Standard Colors - Minimum 1,600 lineal ft. for all colors.



Teak



Moleskin



Rosewood



Ebony

Non-Standard Colors - 90 day lead time - Minimum order 5,000 lineal ft.



Blackwood



Bilinga

Custom Colors Available - Minimum order 6,000 lineal ft.

www.usa.geolam.com
Toll free: 1-877-627-3530
info@geolaminc.com

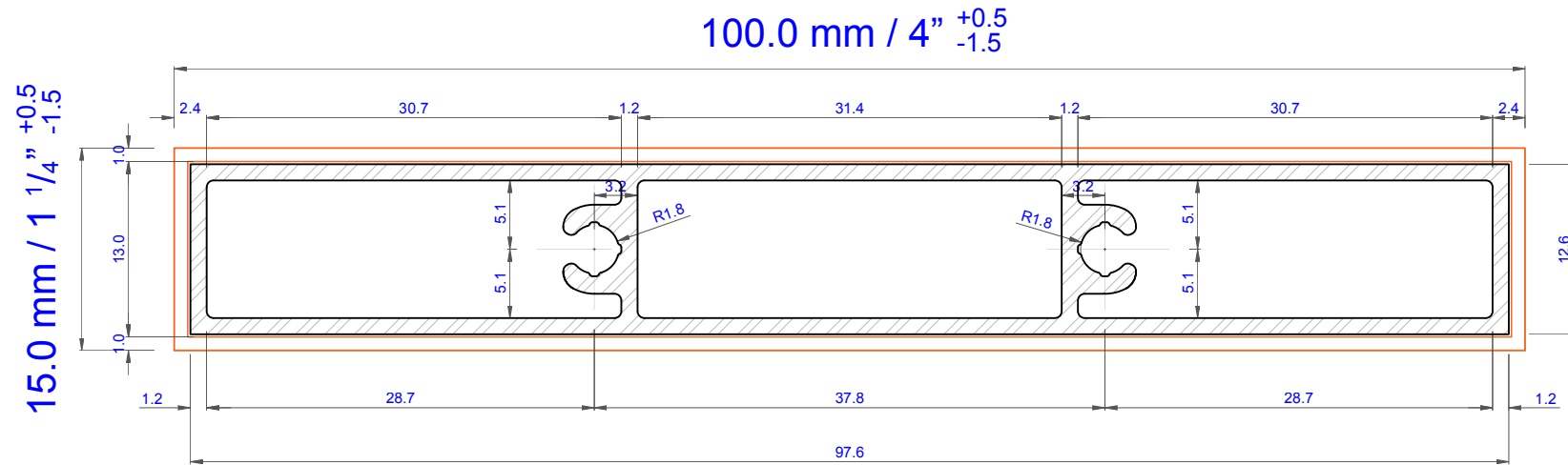

Technical specifications, dimensions in mm		Cross section coefficient Z+x (cm ³)	1.31	Wood hybrid system WHS	Type 1.0
Weight (kg/ml)	1.00	Cross section coefficient Z-x (cm ³)	1.31	Soleo 6036 www.geolaminc.com	
Cross section, secondary moment Ix (cm ⁴)	26.05	Cross section coefficient Z+y (cm ³)	5.34		
Cross section, secondary moment Iy (cm ⁴)	0.82	Cross section coefficient Z-y (cm ³)	5.34		