

# Soleo 6029

**Geolam**<sup>®</sup>  
Architectural Eco-Technology

## Hybrid Aluminum/WPC Architectural Elements

Datasheet

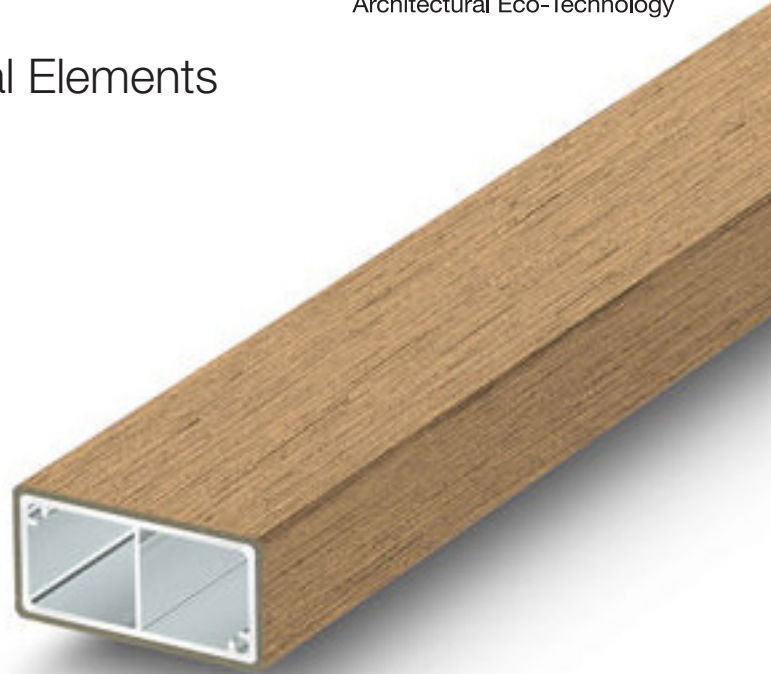
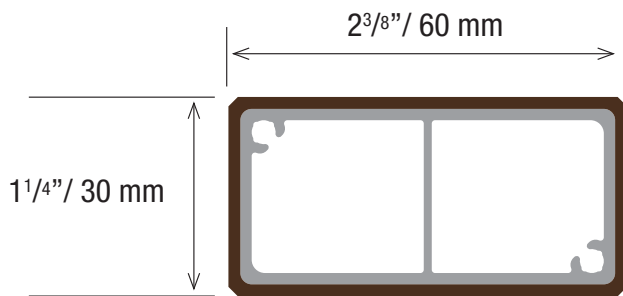

*Technical information may change without warning.  
Please ensure you that you reference our latest as shown on our website at [www.usa.geolam.com](http://www.usa.geolam.com)*

**Thickness:** 1 1/4 in | 30 mm

**Width:** 2 3/8 in | 60 mm

**Section tolerances in mm:** + 0.5 / - 2.0

**Fire rating:**

On request before order

**Surfaces finish:** Sanded

**Profiles fastening and installation:**

Check our website [www.usa.geolam.com](http://www.usa.geolam.com)

**Standard length:** 9 ft 10 in | 3.0 m

**Or order custom lengths from:**

7 ft to 19 ft 8 in | 2.15 m to 6 m

**Weight:** 0.67 lb/ft | 1.00 kg/m

**Secondary moment Ix (cm<sup>4</sup>):** 3.08

**Secondary moment Iy (cm<sup>4</sup>):** 10.41

**Section modulus Z+x (cm<sup>3</sup>):** 2.37

**Section modulus Z-x (cm<sup>3</sup>):** 2.37

**Section modulus Z+y (cm<sup>3</sup>):** 3.72

**Section modulus Z-y (cm<sup>3</sup>):** 3.72

**Core in anodized aluminum alloy:**

A6063S-T5 Serie 6000

**Coefficient of Thermal Expansion (20-100°C):**

23.4 µm/m/°C

**Modulus of Elasticity:** 68.9 GPa

**Max Tensile Strength:** 186 Mpa

**Carbon Footprint:**

WPC : 1.54 kg CO<sub>2</sub> /Kg

Profile : 9.005 kg CO<sub>2</sub> /Kg

*Sanding finish and/or shading may vary between runs*

**Standard Colors** - Minimum 1,000 lineal ft. for all colors.



Teak



Moleskin



Rosewood



Ebony

**Non-Standard Colors** - 90 day lead time - Minimum order 5,000 lineal ft.



Blackwood



Bilinga

**Custom Colors Available** - Minimum order 6,000 lineal ft.

[www.usa.geolam.com](http://www.usa.geolam.com)  
Toll free: 1-877-627-3530  
[info@geolaminc.com](mailto:info@geolaminc.com)

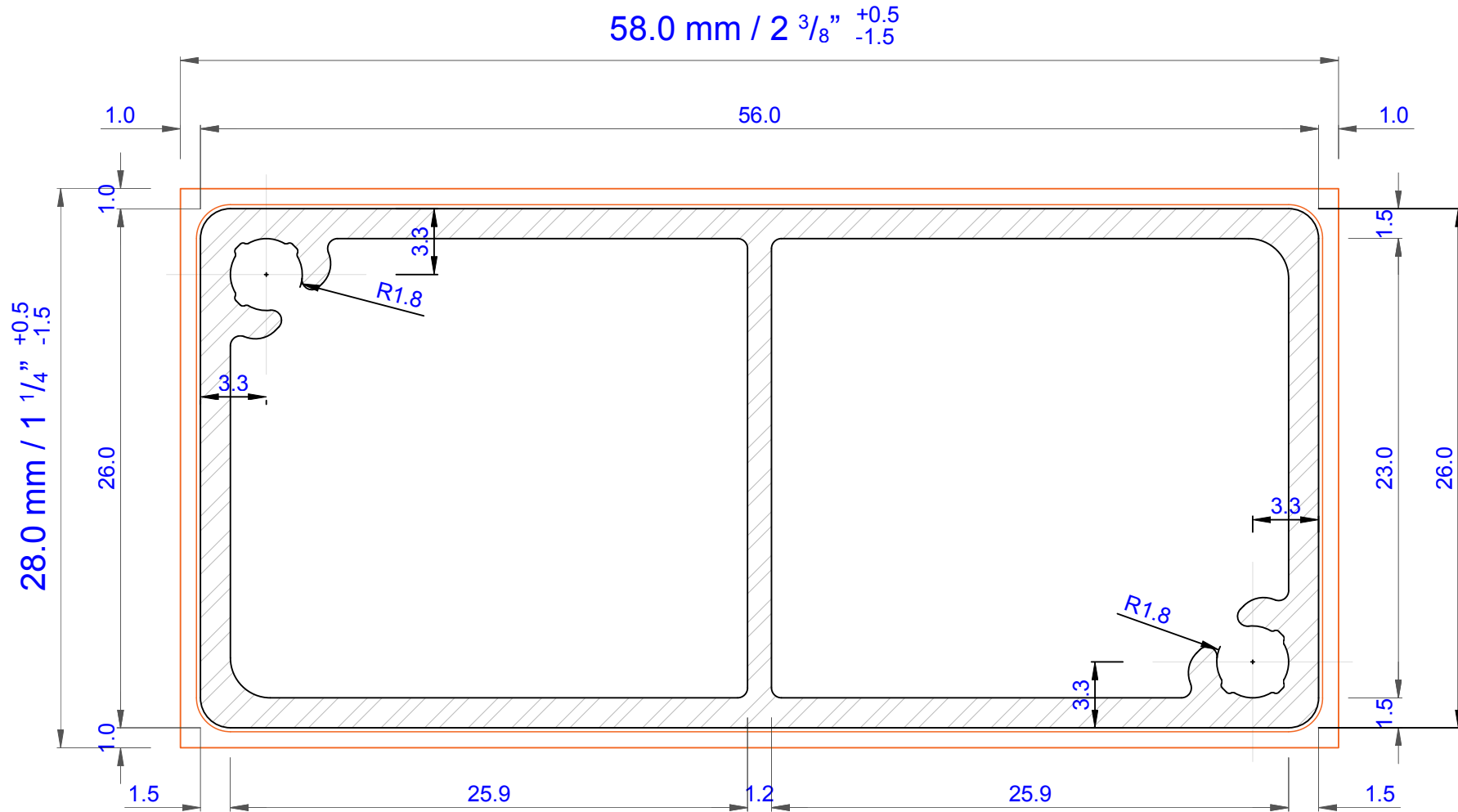

<b>Technical specifications, dimensions in mm</b>		Cross section coefficient Z+x (cm <sup>3</sup> )	2.37	<b>Wood hybrid system WHS</b>	Type 1.0
Weight (kg/ml)	1.00	Cross section coefficient Z-x (cm <sup>3</sup> )	2.37	<b>Soleo 6029</b>	
Cross section, secondary moment Ix (cm <sup>4</sup> )	10.43	Cross section coefficient Z+y (cm <sup>3</sup> )	3.72		
Cross section, secondary moment Iy (cm <sup>4</sup> )	3.08	Cross section coefficient Z-y (cm <sup>3</sup> )	3.72		
<b>Geolam</b> www.geolaminc.com					