

Planeo 4062

Geolam[®]
Architectural Eco-Technology

Hybrid Aluminum/WPC Architectural Elements

Datasheet

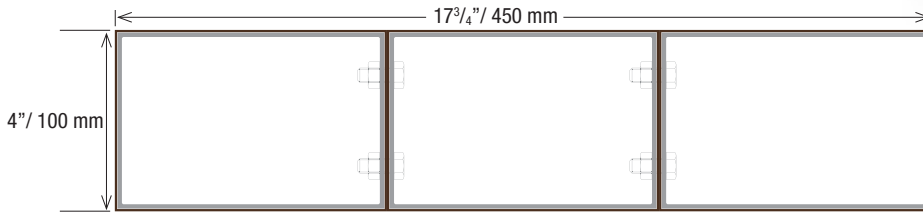
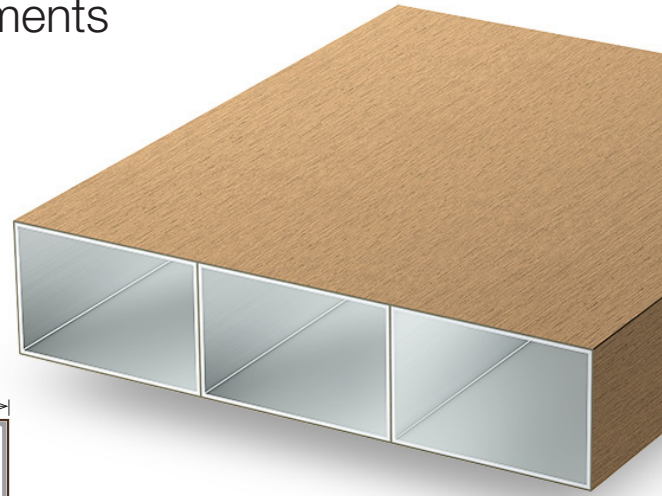

*Technical information may change without warning.
Please ensure you that you reference our latest as shown on our website at www.usa.geolam.com*

Thickness: 4 in | 30 mm
Width: 17 3/4 in | 435 mm
Section tolerances in mm: + 0.5 / - 2.0

Fire rating:
On request before order

Surfaces finish: Sanded

Profiles fastening and installation:
Check our website www.usa.geolam.com

Standard length: 9 ft 10 in | 3.0 m

On order any length from:
7 ft to 27 ft | 2.15 m to 8.25 m

Weight: 9.54 lb/ft | 14.25 kg/m

Secondary moment Ix (cm⁴): 568.29

Secondary moment Iy (cm⁴): 6247.14

Section modulus Z+x (cm³): 117.17

Section modulus Z-x (cm³): 117.17

Section modulus Z+y (cm³): 279.51

Section modulus Z-y (cm³): 279.51

Core in anodized aluminum alloy:
A6063S-T5 Serie 6000

Coefficient of Thermal Expansion (20-100°C):
23.4 μm/m/°C

Modulus of Elasticity: 68.9 GPa

Max Tensile Strength: 186 Mpa

Carbon Footprint:
WPC : 1.54 kg CO₂ /Kg
Profile : 9.005 kg CO₂ /Kg

IMPORTANT:

Planeo boards consist of other Geolam hybrid profiles, usually Soleo, that are bolted internally to produce a larger board. The bolts are usually placed 2 – 4 ft apart depending on the profile and are inset approx 2" at the end of each board. The boards can be field cut with a small tooth saw to shorten them but only the 2" on the ends that stick out past the end bolts. Please do not cut these boards anywhere else. This may compromise the structural integrity of the board.

Sanding finish and/or shading may vary between runs

Standard Colors - Minimum 550 lineal ft. for all colors.



Teak



Moleskin



Rosewood



Ebony

Non-Standard Colors - 90 day lead time - Minimum order 5,000 lineal ft.



Blackwood



Bilinga

Custom Colors Available - Minimum order 6,000 lineal ft.

www.usa.geolam.com
Toll free: 1-877-627-3530
info@geolaminc.com

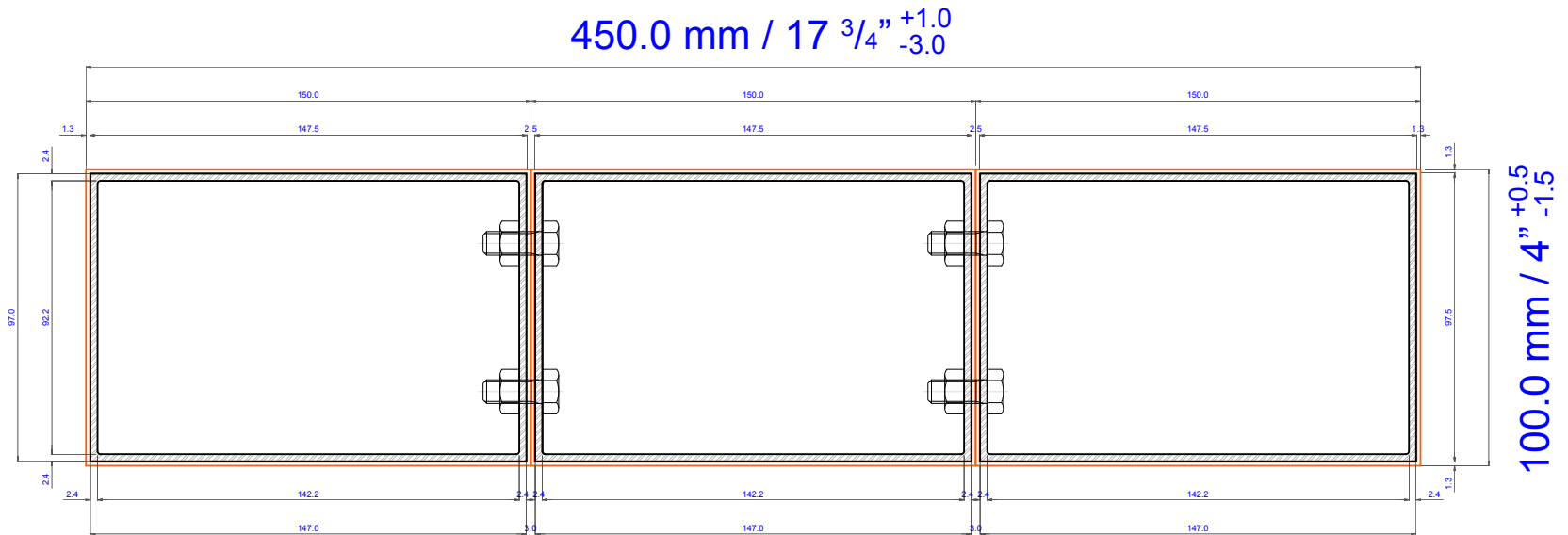

Technical specifications, dimensions in mm		Cross section coefficient Z+x (cm ³)	117.17	Wood hybrid system WHS	Type 1.0
Weight (kg/ml)	14.25	Cross section coefficient Z-x (cm ³)	117.17	Planeo 4062	
Cross section, secondary moment Ix (cm ⁴)	568.29	Cross section coefficient Z+y (cm ³)	279.51		
Cross section, secondary moment Iy (cm ⁴)	6247.14	Cross section coefficient Z-y (cm ³)	279.51		
				Geolam www.geolaminc.com	