

Careo 7035

Geolam[®]
Architectural Eco-Technology

Hybrid Aluminum/WPC Architectural Elements

Datasheet

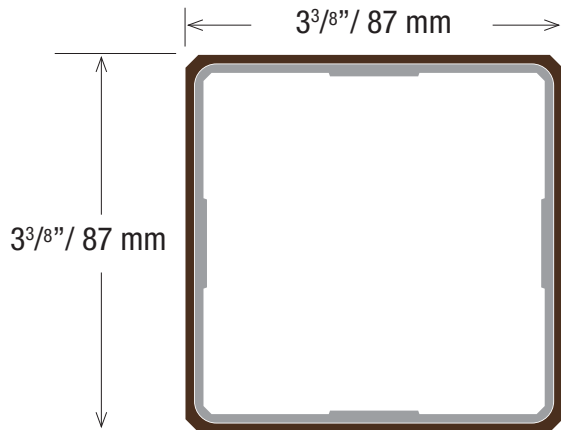

*Technical information may change without warning.
Please ensure you that you reference our latest as shown on our website at www.usa.geolam.com*

Thickness: 3 3/8 in | 87 mm
Width: 3 3/8 in | 87 mm
Section tolerances in mm: + 0.5 / - 2.0

Fire rating:
On request before order

Surfaces finish: Sanded

Profiles fastening and installation:
Check our website www.usa.geolam.com

Standard length: 9 ft 10 in | 3.0 m

Or order custom lengths from:
7 ft to 19 ft 8 in | 2.15 m to 6 m

Weight: 1.53 lb/ft | 2.28 kg/m

Secondary moment Ix (cm⁴): 65.95

Secondary moment Iy (cm⁴): 65.95

Section modulus Z+x (cm³): 15.77

Section modulus Z-x (cm³): 15.77

Section modulus Z+y (cm³): 15.77

Section modulus Z-y (cm³): 15.77

Core in anodized aluminum alloy:
A6063S-T5 Serie 6000

Coefficient of Thermal Expansion (20-100°C):
23.4 µm/m/°C

Modulus of Elasticity: 68.9 GPa

Max Tensile Strength: 186 Mpa

Carbon Footprint:
WPC : 1.54 kg CO₂ /Kg
Profile : 9.005 kg CO₂ /Kg

Sanding finish and/or shading may vary between runs

Standard Colors - Minimum 1,000 lineal ft. for all colors.



Teak



Moleskin



Rosewood



Ebony

Non-Standard Colors - 90 day lead time - Minimum order 5,000 lineal ft.



Blackwood



Bilinga

Custom Colors Available - Minimum order 6,000 lineal ft.



www.usa.geolam.com
Toll free: 1-877-627-3530
info@geolaminc.com

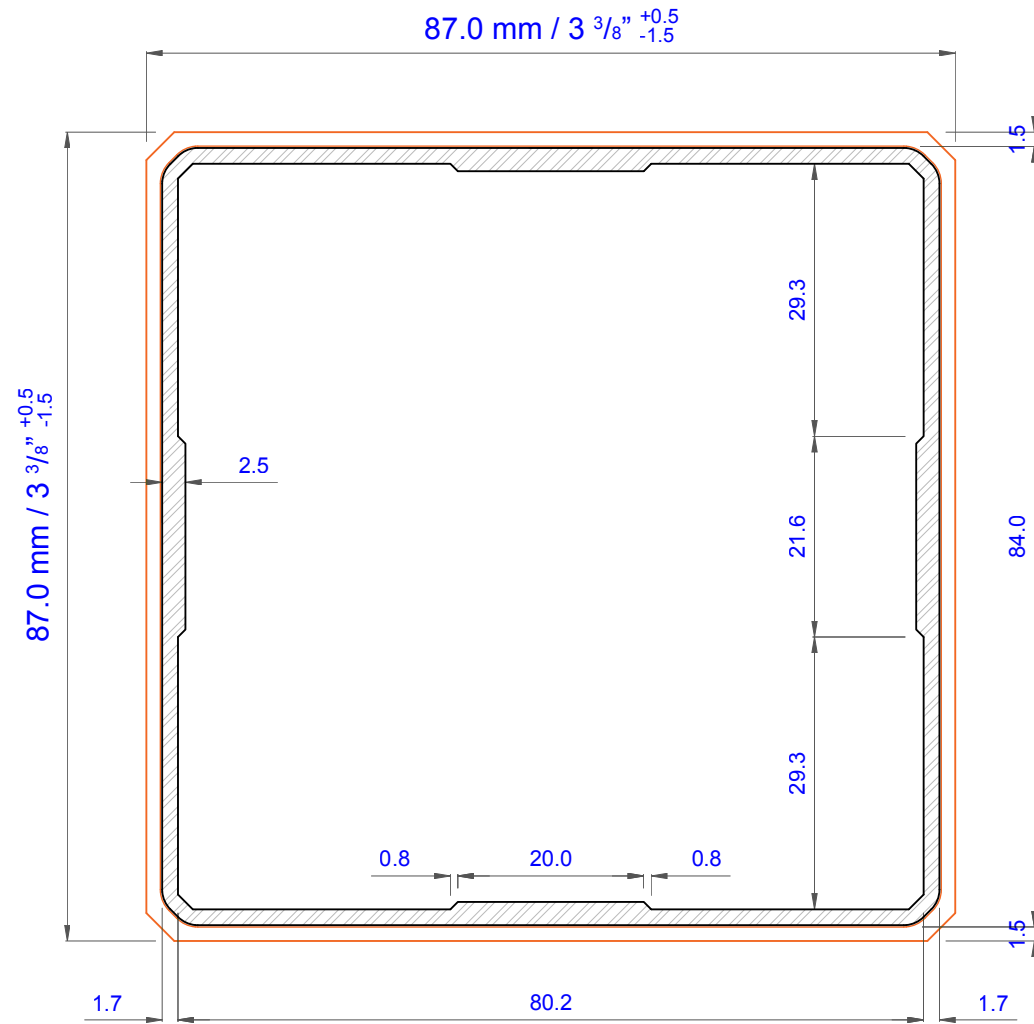

Technical specifications, dimensions in mm		Cross section coefficient Z+x (cm ³)	15.77	Wood hybrid system WHS	Type 1.0
Weight (kg/ml)	2.28	Cross section coefficient Z-x (cm ³)	15.77	Careo 7035 www.geolaminc.com	
Cross section, secondary moment Ix (cm ⁴)	65.95	Cross section coefficient Z+y (cm ³)	15.77		
Cross section, secondary moment Iy (cm ⁴)	69.95	Cross section coefficient Z-y (cm ³)	15.77		